

Flail mowers

Multi-purpose flail mower, Lateral flail mower and Shredders

TriSar

The multi-purpose flail mower are the working tool ideal in all situations, with the best results and the max security: for grass mowing and mulching of vines and wood in vineyards and orchards.



TriLat

The lateral flail mower are the ideal tools for the maintenance of ditches, road sides, meadows and the clearing of banks and clipping of hedges.



TrisToc

The shredders, thanks to their sturdiness are the ideal tool to mulch and shred in the open field: bushes, straw, corn stocks, soy and crop residues, wooden or organic material present on fallow soils.



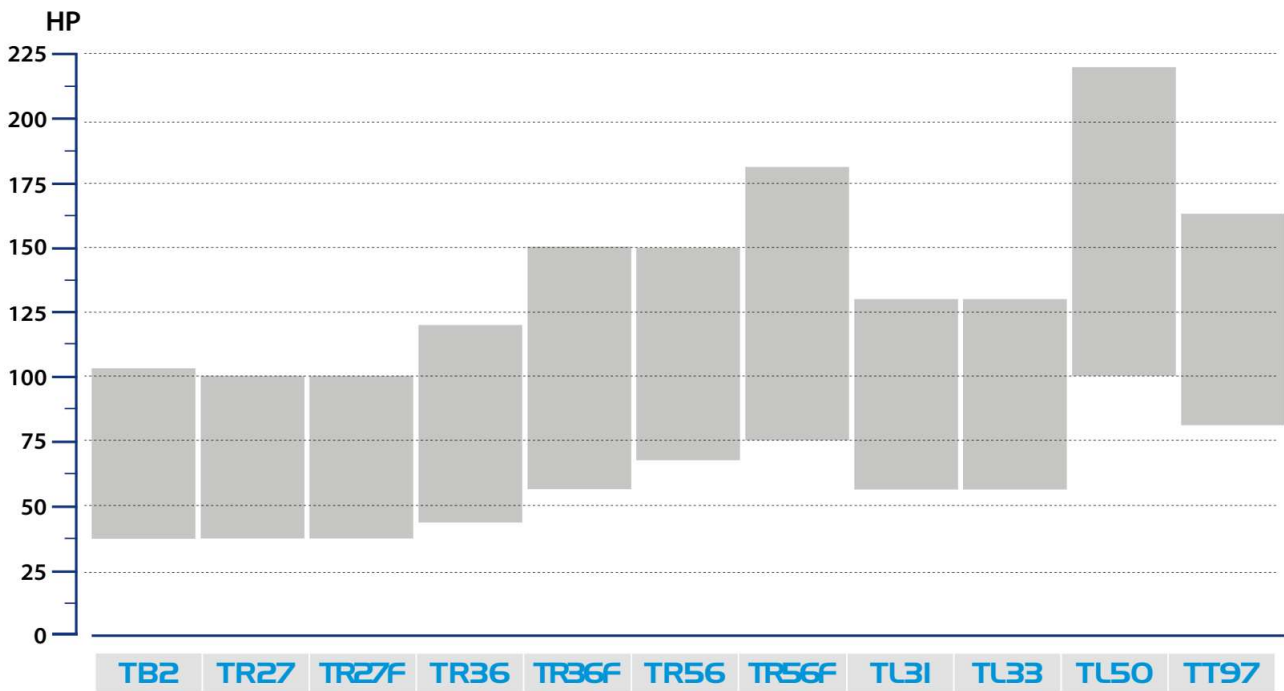

MULCHING CHAMBER SSA

Mulchkamer SSA “Super Shredder Alpego” (gepatenteerd in Italië) multifunctioneel variabel volume, door het wijzigen van de positie van de kap zijn er 2 soorten werkzaamheden mogelijk:

Verhoogd zodat er eenvoudig gemaaid kan worden met afvoer van het product na de wals (gras, struiken maaien, dicht vegetatie...).

Kap blijft laag en de houtachtige resten zijn bijzonder versnipperd en tot het maximum in de kamer blijven het versnipperen wordt bereikt (stoppels, kreupelhout, snoeien, hout...).

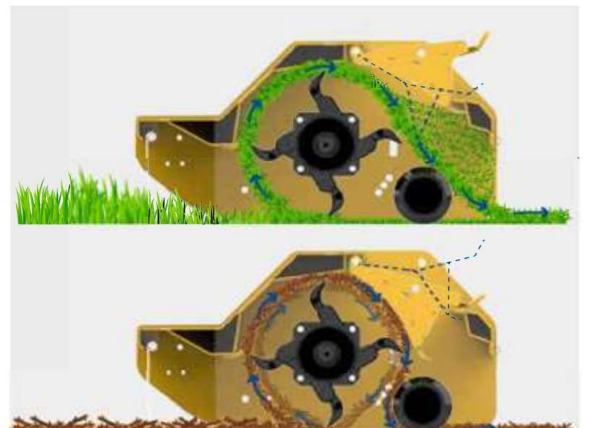

TB2

Flail mower TriSar
with lowered profile
HP 40-105



Kenmerken

Ultralaag ontwerp

Compacte zij-aandrijving met nieuwe transmissieriemen VBHP - SPECIAAL (V-riem-High-Performance)

Nieuwe haakse versnellingsbak

Ultrastevig frame van staal met hoge treksterkte

Rechter afgeronde zijde zonder uitstekende delen

SSA variabele mulchkamer door de interne kantelbare kap

Professionele rotor met gekantelde gereedschapshoudersteunen en zware M18 bouten

Universele zelfslijpende hamers

Zijbeschermers voor planten

Standaard uitvoering

Hydraulische zijdelingse beweging

Aandrijftras met bescherming

Achterrol met beschermde lagers

Vast tegenmes

Aftakas 540 tpm

3-puntshef aankoppeling cat. 1 en 2

Vrijloop in oliebad, geplaatst in de hoofdversnellingsbak

Beschermflappen aan de voorkant

TB2

STANDARD ELEMENTS

Code	Classif.	Mod.	 HP	 mm	 mm	 (n°)	 (n°)	 mm	 Kg	 €
TBVB00006	-	TB2 140	40-90	1400	1550	12	3	140	510	7.730
TBVB00007	-	TB2 160	45-95	1600	1750	14	3	140	540	8.030
TBVB00008	-	TB2 180	50-100	1800	1950	16	3	140	580	8.440
TBVB00009	-	TB2 200	55-105	2000	2150	16	3	140	640	8.640

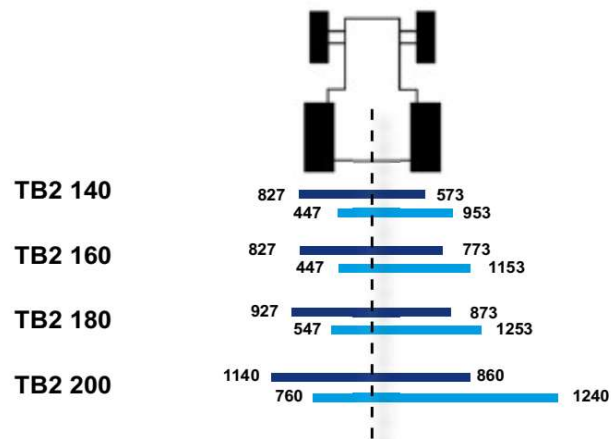

Voor eventuele opties - zie laatste pagina's

NEW TR27

FLAIL MOWERS

Professional multi-purpose
flail mower TriSar
HP 40-100



ROTARY TILLERS

M/S



Kenmerken

- Professionele, versterkte rotor met klepels met M18 bouten
- Compacte zij-aandrijving met nieuwe transmissieriemen VBHP - SPECIAAL (V-riem-High-Performance)
- Mulchkamer "Super Shredder Alpego" ontworpen om zorgen voor een instelbaar mulchvolume.
- Driepuntshefbeweging zonder smering (nul onderhoud)
- Frame met afgeronde rechterkant en zijbeschermers
- Achterkap kan worden geopend voor inspectie en onderhoud
- Zij geleiders voor planten

Standaard uitvoering

- Mechanische of hydraulische zijdelingse beweging - Keuze maken uit de lijst
- Aandrijftras met bescherming
- Achterrol Ø140 met beschermde lagers
- Vast tegenmes
- Aftakas 540 tpm
- 3-puntshef aankoppeling cat. I en II N
- Vrijloop in oliebad, geplaatst in de hoofdversnellingsbak
- Dubbele bescherming voor transmissiepoelies
- Beschermende frontbeschermingskleppen aan de voorkant

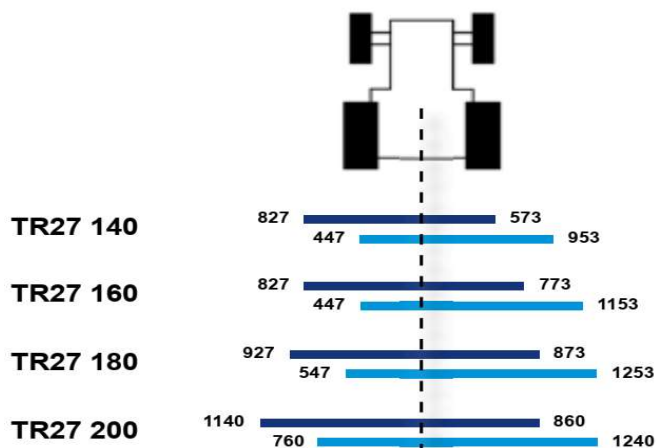

NEW TR27

FLAIL MOWERS

Professional multi-purpose
flail mower TriSar
HP 40-100



ROTARY TILLERS

WS



STANDARD MACHINE

Code	Classif.	Mod.	HP	mm	mm	(n°)	(n°)	mm	Kg	€
TBRP00001	C	TR27 140	40-100	1400	1550	12	3	140	510	6.270
TBRP00002	B	TR27 160	45-100	1600	1750	14	3	140	540	6.470
TBRP00003	B	TR27 180	55-100	1800	1950	16	3	140	590	6.770
TBRP00004	B	TR27 200	55-100	2000	2150	16	3	140	625	6.970

Code	Classif.		Descrizione	Kg	€
S50A00014	B		Mechanic side shift	5	137
S50A00015	B		Hydraulic side shift	10	445
S50A00016	B		Hydraulic side shift (Only for TR27 140-160)	10	445

Veel verkochte uitvoeringen :

Codice A+B	Descrizione	Kg	€
TBRP00001 + S50A00014	TR27 140 + Mechanic side shift	515	6.407
TBRP00001 + S50A00016	TR27 140 + Hydraulic side shift	520	6.715
TBRP00002 + S50A00014	TR27 160 + Mechanic side shift	545	6.607
TBRP00002 + S50A00016	TR27 160 + Hydraulic side shift	550	6.915
TBRP00003 + S50A00014	TR27 180 + Mechanic side shift	595	6.907
TBRP00003 + S50A00015	TR27 180 + Hydraulic side shift	600	7.215
TBRP00004 + S50A00014	TR27 200 + Mechanic side shift	630	7.107
TBRP00004 + S50A00015	TR27 200 + Hydraulic side shift	635	7.415

Voor eventuele opties - zie laatste pagina's

NEW TR27 F

FLAIL MOWERS

Professional front mounted multi-purpose flail mower TriSar HP 40-100



Frontuitvoering van de TR 27

Code	Classif.	Mod.	HP	mm	mm	(n°)	(n°)	mm	Kg	€
TBRP00005	C	TR27F 140	40-100	1400	1550	12	3	140	525	6.670
TBRP00006	B	TR27F 160	45-100	1600	1750	14	3	140	555	6.870
TBRP00007	B	TR27F 180	55-100	1800	1950	16	3	140	605	7.180
TBRP00008	B	TR27F 200	55-100	2000	2150	16	3	140	640	7.380



Optioneel is de TR-27F te verkrijgen met een extra bok voor gebruik achter de tractor

Voor eventuele opties - zie laatste pagina's

Code	Classif.	Description	Mod.	Q.ty	Kg	€
S45A00094	-	Double Linkage kit for TR27F (allows rear mounting of the flail mower)	TR27F	x 1	50	570

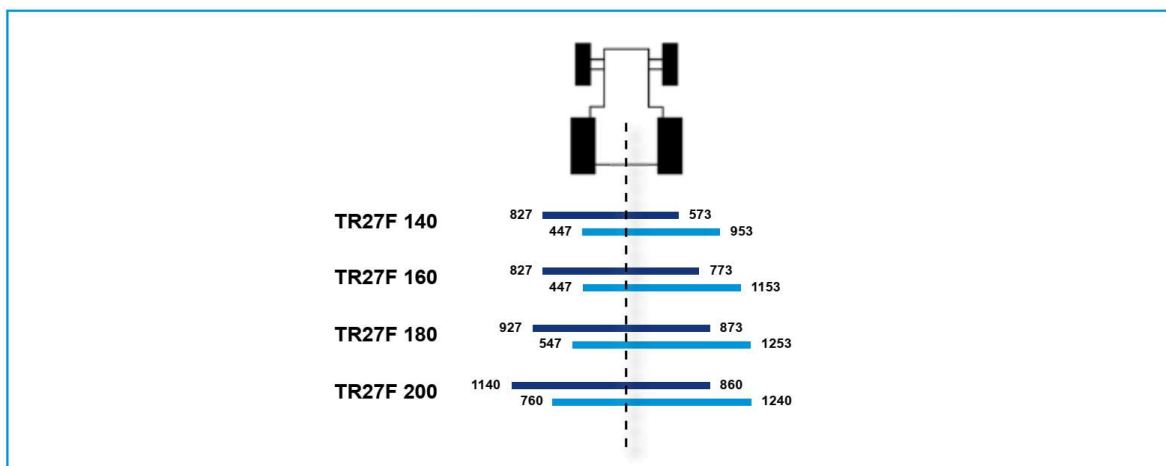

TR36



FLAIL MOWERS

ROTARY TILLERS

OWS

Multi-purpose flail mower
Rear mounted TriSar
HP 45-120



Kenmerken

Grotere hamerrotor

Mulchkamer "Super Shredder Alpego" ontworpen om te zorgen voor een instelbaar mulchvolume:

- a) voor het mulchen van gras, snelle afvoer;
- b) "Turbomulching"-positie voor het mulchen van hout

Driepuntshefbeweging zonder smering (nul onderhoud)

Frame met afgeronde rechterkant en zijbeschermers

Intern tegenframe (dubbel blad)

Achterkap kan worden geopend voor inspectie en onderhoud

Stalen frame met hoge treksterkte

Standaard uitvoering

Hydraulische zijdelingse beweging

Aandrijfjas met bescherming

Achterrol Ø160 met beschermde lagers

Vast tegenmes

Tweede tegenmes

Aftakas 540 tpm

Ook leverbaar met 1000 tpm aftakas - Op aanvraag

3-puntshef aankoppeling cat. 2

Vrijloop in oliebad, geplaatst in de hoofdversnellingsbak

Dubbele bescherming voor transmissiepoelies

Beschermende frontbeschermingskleppen aan de voorkant

TR36

Code	Classif.	Mod.	 HP	 mm	 mm	 (n°)	 (n°)	 mm	 Kg	 €
TBSN00011	B	TR36 160	45-105	1600	1750	14	4	160	695	8.390
TBSN00012	A	TR36 180	50-105	1800	1950	16	4	160	740	8.890
TBSN00013	A	TR36 200	55-120	2000	2150	16	4	160	775	9.350
TBSN00014	A	TR36 220	60-120	2200	2350	20	4	160	825	9.900
TBSN00015	B	TR36 240	65-120	2400	2550	20	4	160	865	10.510



Optioneel is de TR56-280 te verkrijgen met een extra penrenrek met schrapers

Code	Classif.	Description	Mod.	Q.ty	Kg	€
S70A00038	C 	Set of 10 rear rakes (complete with mud-scraper)	TR36 160	x 1	27	375
S70A00039		Set of 11 rear rakes (complete with mud-scraper)	TR36 180	x 1	32	400
S70A00040		Set of 12 rear rakes (complete with mud-scraper)	TR36 200	x 1	35	415
S70A00041		Set of 14 rear rakes (complete with mud-scraper)	TR36 220	x 1	40	485
S70A00042		Set of 15 rear rakes (complete with mud-scraper)	TR36 240	x 1	55	501

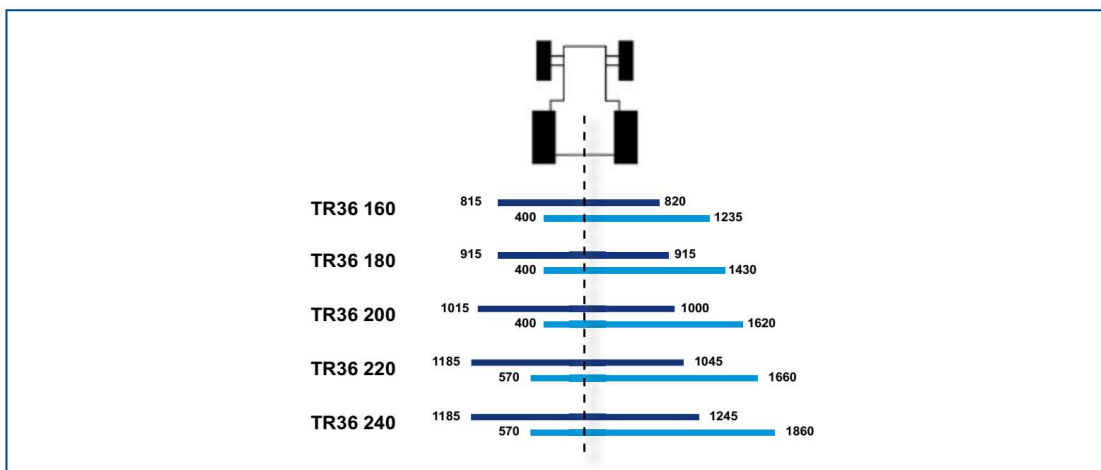

Voor eventuele opties - zie laatste pagina's

TR36 F



FLAIL MOWERS

Multi-purpose flail mower
Front/rear mounted TriSar
HP 55-150



ROTARY/TILLERS

TOWS

Frontuitvoering van de TR 36 - Standaard met dubbele bok

DOUBLE 3-POINT HITCH

The double 3-point hitch on the TR36F/ TR56F ensures both front and rear applications on the machine.



STANDARD MACHINE

Code	Classif.	Mod.	HP	mm	mm	(n°)	(n°)	mm	Kg	€
TBSN00017	A	TR36F 180	55-150	1800	1950	16	4	160	800	10.410
TBSN00018	A	TR36F 200	60-150	2000	2150	16	4	160	890	10.760
TBSN00019	A	TR36F 220	65-150	2200	2350	20	4	160	980	11.420
TBSN00020	B	TR36F 240	70-150	2400	2550	20	4	160	1020	12.180

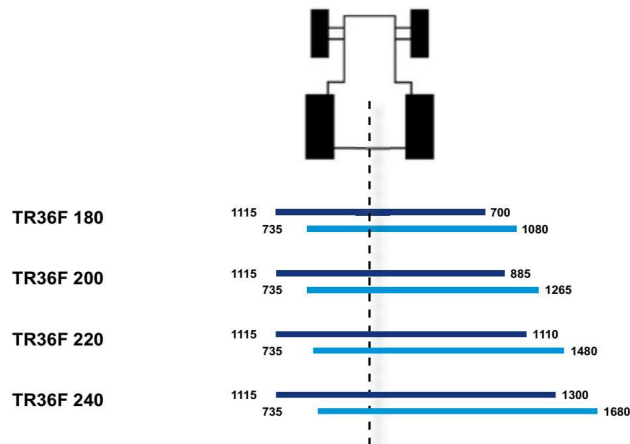

Voor eventuele opties - zie laatste pagina's

TR56



FLAIL MOWERS

Multi-purpose flail mower
Rear mounted TriSar
HP 70-150

ROTARYTILLERS

PROWS



Kenmerken

Grotere hamerrotor

Mulchkamer "Super Shredder Alpego" ontworpen om te zorgen voor een instelbaar mulchvolume

a) voor het mulchen van gras, snelle afvoer;

b) "Turbomulching"-positie voor het mulchen van hout

Driepuntshefbeweging zonder smering (nul onderhoud)

Frame met afgeronde rechterkant en zijbeschermers

Intern tegenframe (dubbel blad)

Achterkap kan worden geopend voor inspectie en onderhoud

Stalen frame met hoge treksterkte

Standaard uitvoering

Hydraulische zijdelingse beweging

Aandrijfvas met bescherming

Achterrol Ø160 met beschermdde lagers

Vast tegenmes - 2e tegenmes

Aftakas 1000 tpm

3-puntshef aankoppeling cat. 2

Vrijloop in oliebad, geplaatst in de hoofdversnellingsbak

Dubbele bescherming voor transmissiepoelies

Beschermende frontbeschermingskleppen aan de voorkant

TR56

STANDARD MACHINE

Code	Classif.	Mod.	 HP	 mm	 mm	 (n°)	 (n°)	 mm	 Kg	 €
TBVC00001	A	TR56 280	70-150	2800	2950	24	5	160	985	11.370
TBVC00004	A	TR56 310	70-150	3100	3250	28	5	160	1055	13.040

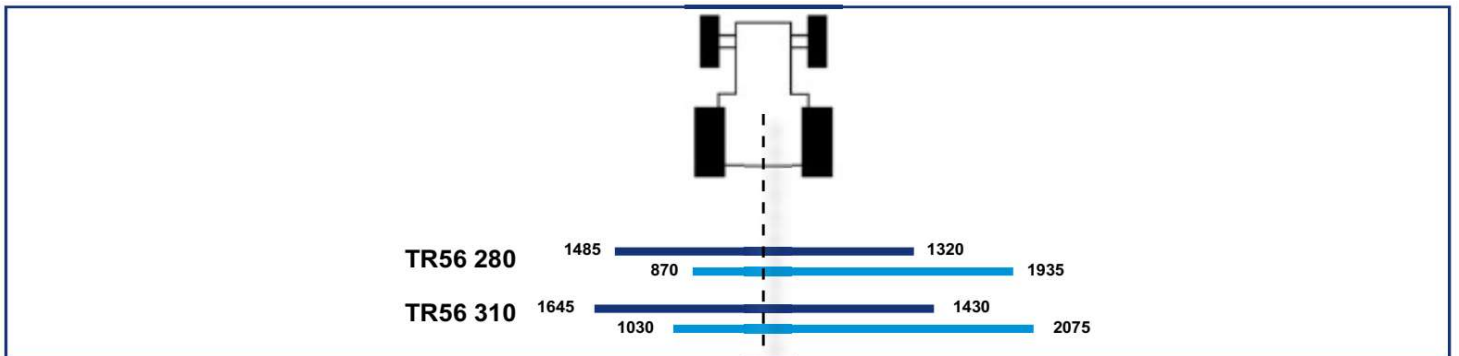

Optioneel is de TR56-280 te verkrijgen met een extra pennenrek met schrapers

S70A00043	Set of 17 rear rakes (complete with mud-scraper)	TR56 280	x 1	58	576
------------------	---	-----------------	-----	----	------------

Voor eventuele opties - zie laatste pagina's

TR56 F



Multi-purpose flail mower
Front/rear mounted TriSar
HP 75-180

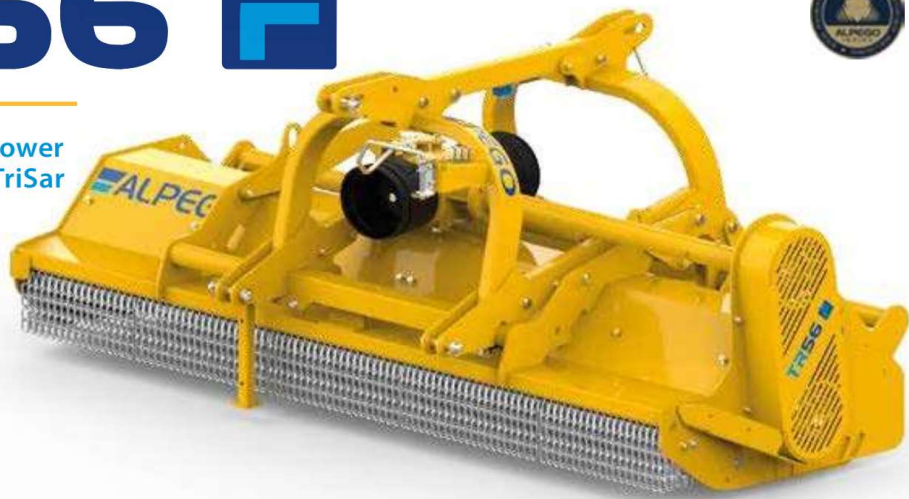

Frontuitvoering van de TR56 - standaard met dubbele bok

DOUBLE 3-POINT HITCH

The double 3-point hitch on the TR36F/ TR56F ensures both front and rear applications on the machine.



STANDARD MACHINE

Code	Classif.	Mod.	HP	mm	mm	(n°)	(n°)	mm	Kg	€
TBVC00002	B	TR56F 280	75-180	2800	2950	24	5	160	1140	13.690
TBVC00003	-	TR56F 310	80-180	3100	3250	28	5	160	1210	15.310

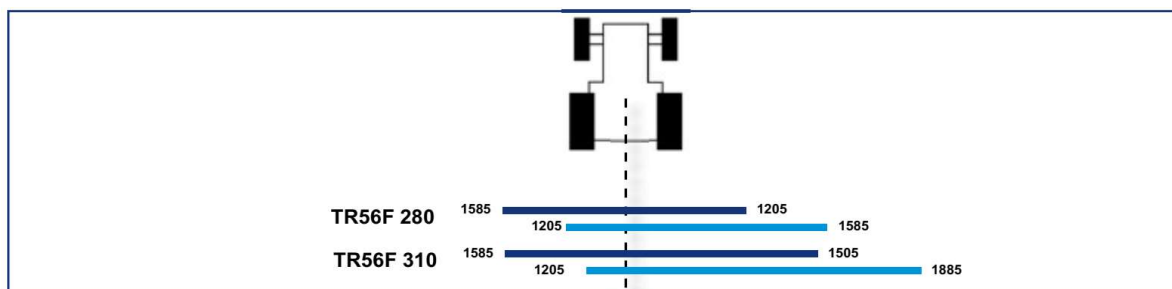

Voor eventuele opties - zie laatste pagina's



Kenmerken

Uitgebreide hydraulische zijdelingse beweging met blokkeerklep

Zelfnivellerende hydraulische schokdemper

Elastisch anti-shock veiligheidssysteem

Intern tegenframe (dubbel blad)

Versnellingsbak intern geïntegreerd

Hydraulisch kantelen met veiligheidsventiel

Kleppen voor de snelheidsregeling van de hydraulische cilinders

3-puntshef aankoppeling met "No-Stop" elastische anti-schokveiligheidssysteem

Ingebouwde rotorsteunen

Stalen frame met hoge treksterkte

Standaard uitvoering

Rotor met hamers en grotere bouten

Aandrijf-as MOET WORDEN GEKOZEN - (NIET INBEGREPEN IN DE PRIJS) - Zie tabel B

Achterrol Ø140 met intern beschermde lagers gemonteerd

Vast tegenmes

Paar skids

Aftakas 540 tpm

3-puntshefaankoppeling cat. 2 met vorkvormige aankoppelhaken

Vrijloop in oliebad, geplaatst in de hoofdversnellingsbak

Hydraulisch schokdempersysteem

Transportframe van de machine (verticale positie)

Beschermende frontbeschermingskleppen aan de voorkant

STANDARD MACHINE

Code	Classif.	Mod.	HP	mm	mm	mm	(n°)	(n°)	mm	Kg	€
TBXA00015	C	TL31 160	55-130	1600	1800	1500	14	4	140	700	9.800
TBXA00016	A	TL31 180	65-130	1800	2000	1500	16	4	140	730	10.100
TBXA00017	A	TL31 200	75-130	2000	2200	1500	16	4	140	750	10.410
TBXA00018	C	TL31 220	75-130	2200	2400	1500	18	4	140	815	10.760

DRIVE SHAFT (REQUIRED: TO BE CHOSEN)

Code	Classif.	Description	Kg	€
M70A00074	C	Drive shaft with protection L=1950	35	640
M73A00001	A	Double Homokinetic drive shaft L=1960	40	1.840

STANDARD MACHINE CONFIGURATION + DRIVE SHAFT

Code A+B	Description	Kg	€
TBXA00015 + M73A00001	TL31 160 + Double Homokinetic drive shaft	740	11.640
TBXA00016 + M73A00001	TL31 180 + Double Homokinetic drive shaft	770	11.940
TBXA00017 + M73A00001	TL31 200 + Double Homokinetic drive shaft	790	12.250
TBXA00018 + M73A00001	TL31 220 + Double Homokinetic drive shaft	855	12.600

The image shows two views of the TL31 combine harvester with its front-mounted harvester head. The top view shows the harvester head in a vertical position, with dimensions A, B, C, and D indicated. Dimension A is the height from the ground to the top of the harvester head. Dimension B is the width of the harvester head. Dimension C is the height from the ground to the bottom of the harvester head. Dimension D is the height from the top of the harvester head to the top of the combine's body. The bottom view shows the harvester head in a horizontal position, with dimensions E and F indicated. Dimension E is the height from the ground to the top of the harvester head. Dimension F is the width of the harvester head. The rotation angles of 90° and 65° are also shown.

	TL31 160	TL31 180	TL31 200	TL31 220
A (mm)	1600	1800	2000	2200
B (mm)	1820	1860	1860	1860
C (mm)	770	770	770	770
D (mm)	2350	2550	2750	2950
E (mm)	930	1130	1330	1530
F (mm)	1700	1700	1700	1700

TL33



FLAIL MOWERS

ROTARY TILLERS

Lateral flail mower TriLat HP 55-130



Kenmerken

- Uitgebreide hydraulische zijdelingse beweging met blokkeerklap
- Zelfnivellerende hydraulische schokdemper
- Elastisch anti-shock veiligheidssysteem
- Intern tegenframe (dubbel blad)
- Versnellingsbak extern geplaatst
- Hydraulisch kantelen met veiligheidsventiel*
- Kleppen voor de snelheidsregeling van de hydraulische cilinders
- 3-puntshef aankoppeling met "No-Stop" elastische anti-schokveiligheidssysteem
- Ingebouwde rotorsteunen
- Stalen frame met hoge treksterkte

Standaard uitvoering

- Rotor met hamers en grotere bouten
- Aandrijftras MOET WORDEN GEKOZEN - (NIET INBEGREPEN IN DE PRIJS) - Zie tabel B
- Achterrol Ø140 met intern beschermde lagers gemonteerd
- Vast tegenmes
- Paar skids
- Aftakas 540 tpm
- 3-puntshefaankoppeling cat. 2 met vorkvormige aankoppelhaken
- Vrijloop in oliebad, geplaatst in de hoofdversnellingsbak
- Hydraulisch schokdempersysteem
- Transportframe van de machine (verticale positie)
- Beschermende frontbeschermingskleppen aan de voorkant



TL33

STANDARD ELEMENTS: Combine (A + B)

STANDARD MACHINE

A	Code	Classif.	Mod.	 HP	 mm	 mm	 mm	 (n°)	 (n°)	 mm	 Kg	 €
		TBZA00015	C	TL33 160	55-130	1600	2100	1500	14	4	140	720
	TBZA00016	A	TL33 180	65-130	1800	2300	1500	16	4	140	750	10.410
	TBZA00017	A	TL33 200	75-130	2000	2500	1500	16	4	140	770	10.760
	TBZA00018	B	TL33 220	75-130	2200	2700	1500	18	4	140	810	11.110

DRIVE SHAFT (REQUIRED: TO BE CHOSEN)

B	Code	Classif.		Description	Kg	€
		M70A00074	C		Drive shaft with protection L=1950	35
	M73A00001	A		Double Homokinetic drive shaft L=1960	40	1.840

STANDARD MACHINE CONFIGURATION + DRIVE SHAFT

Code A+B	Description	Kg	€
TBZA00015 + M73A00001	TL33 160 + Double Homokinetic drive shaft	760	11.940
TBZA00016 + M73A00001	TL33 180 + Double Homokinetic drive shaft	790	12.250
TBZA00017 + M73A00001	TL33 200 + Double Homokinetic drive shaft	810	12.600
TBZA00018 + M73A00001	TL33 220 + Double Homokinetic drive shaft	850	12.950

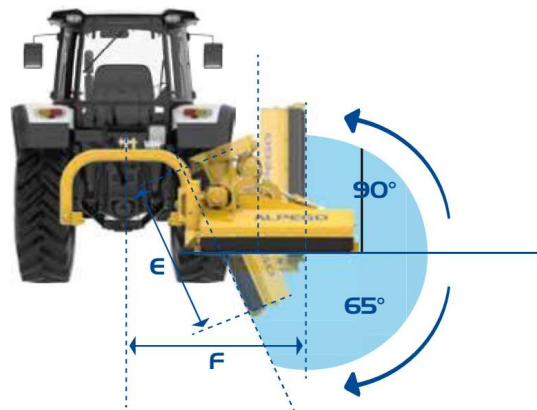
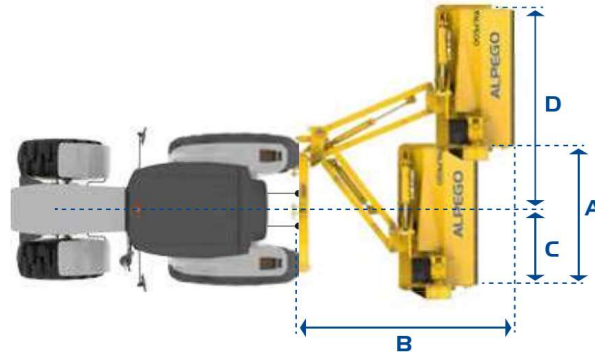

	TL33 160	TL33 180	TL33 200	TL33 220
A (mm)	1600	1800	2000	2200
B (mm)	1820	1860	1860	1860
C (mm)	580	580	580	580
D (mm)	2540	2740	2940	3140
E (mm)	1100	1300	1500	1700
F (mm)	1700	1700	1700	1700

NEW TL50

Heavy-duty side flail mower TriLat
HP 100-220 / KW 74-163



Kenmerken

- Hydraulische zijdelingse beweging behoort tot de grootste in zijn soort - klasse
- Gegarandeerd veilige wielpositie op het loopvlak
- Zelfnivellerende hydraulische schokdemper
- Elastisch anti-shock veiligheidssysteem
- Intern tegenframe (dubbel blad)
- Externe, aan de achterzijde gemonteerde versnellingsbakconstructie voor optimaal zwaartepunt
- Brede hydraulische helling (+90° / -65°) met veiligheidsventiel
- Kleppen voor de snelheidsregeling van de hydraulische cilinders
- 3-puntshefinrichting met "No-Stop" elastische anti-schokveiligheidssysteem
- Ingebouwde rotorsteunen
- Stalen frame met hoge treksterkte

Standaard uitvoering

- Nieuwe 0194 mm rotor met vergrote hamers en bouten
- Dubbele homokinetische aandrijfassen
- Achterrol Ø160 met intern beschermde lagers gemonteerd
- Vast tegenmes
- Paar skids
- Aftakas 540 tpm
- 3-puntshef aankoppeling cat. 2 en 3 met vorkvormige aankoppelhaken
- Vrijloop in oliebad, geplaatst in de hoofdversnellingsbak
- Hydraulisch schokdempersysteem
- Transportframe van de machine (verticale positie)
- Beschermende frontbeschermingskleppen aan de voorkant

Let op:

Voor een correcte koppeling aan de trekker dient u altijd de spoorbreedte en het minimale gewicht van de tractor te controleren

NEW TL50

STANDARD ELEMENTS

Code	Classif.	Mod.	 HP	 mm	 mm	 (n°)	 (n°)	 mm	 Kg	 €
TBZR00001	B	TL50 200	100-220	2000	2527	16	5	160	1165	16.470
TBZR00002	B	TL50 220	100-220	2200	2740	20	5	160	1210	16.870
TBZR00003	B	TL50 240	100-220	2400	2972	20	5	160	1240	17.930
TBZR00004	B	TL50 260	100-220	2600	3157	22	5	160	1280	18.240

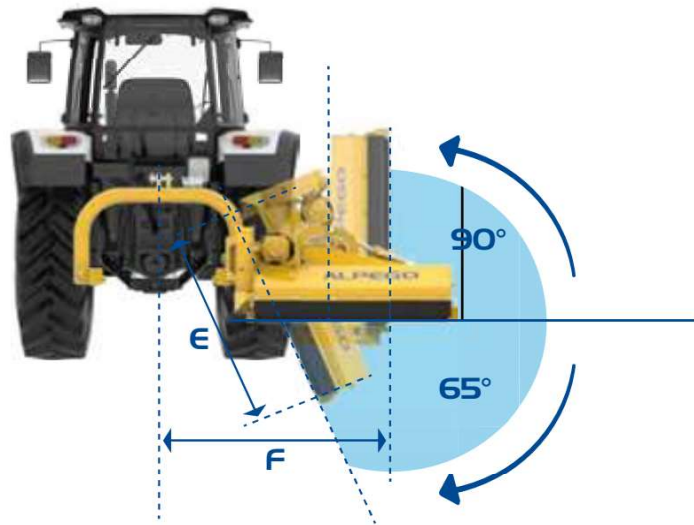
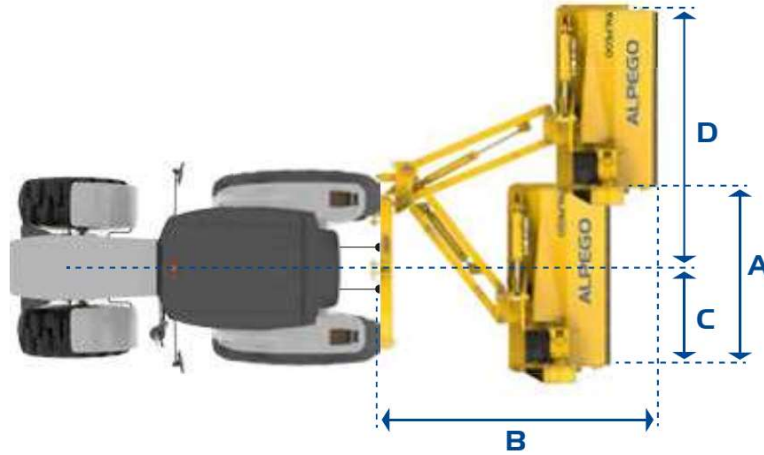

	TL50 200	TL50 220	TL50 240	TL50 260
A (mm)	2000	2213	2415	2600
B (mm)	2004	2004	2004	2004
C (mm)	589	589	589	589
D (mm)	3156	3369	3571	3756
E1 (mm)	1509	1722	1924	2109
E2 (mm)	1332	1545	1747	1932
E3 (mm)	1062	1275	1477	1662
F (mm)	2125	2125	2125	2125

TT97

Shredders-Straw mulchers TrisToc
HP 80-160 / KW 60-120



MULCHERS

ROTARY CULTIVATORS

Kenmerken

- Monocoque frame, geen las- en naden zichtbaar
- Frame zonder uitstekende delen en met binnenrotorsteunen
- Achterkap: kan geopend worden voor onderhoud
- Mogelijkheid om slijtvaste bescherming te installeren (te kiezen bij ACCESSOIRES)
- Hoofdtegenmes ingebed in het frame
- Stalen frame met hoge treksterkte

Standaard uitvoering

- Machine met hamer of klepelrotor - keuze maken in de uitvoering
- Aandrijftras met bescherming
- Dieptecontrole - VERPLICHT MOET GEKOZEN WORDEN - Zie tabel B
- Aandrijving PTO 1000 rpm
- Vrijloop in oliebad, geplaatst in de hoofdversnellingsbak
- 3-puntshef aankoppeling cat. 2
- Zijplaten
- Beschermingskettingen aan de voorkant

TT97

STANDARD ELEMENTS: Combine (A + B)

Code	Classif.	Mod.	STANDARD MACHINE								
			HP	mm	mm	(n°)	(n°)	(n°)	mm	Kg	€
STANDARD MACHINE WITH FLAILS											
TCCN00001	C	TT97 280	80-160	2800	3000	-	60	5	220	1070	11.270
TCCN00003	C	TT97 300	90-160	3000	3200	-	64	5	220	1120	12.070
TCCN00005	C	TT97 320	100-160	3200	3400	-	68	5	220	1180	13.790
STANDARD MACHINE WITH HAMMERS											
TCCN00002	C	TT97 280	80-160	2800	3000	30	-	5	220	1050	11.270
TCCN00004	C	TT97 300	90-160	3000	3200	32	-	5	220	1100	12.070
TCCN00006	C	TT97 320	100-160	3200	3400	34	-	5	220	1150	13.790

Code	Classif.	Mod.	DEPTH CONTROL (COMPULSORY: TO BE CHOSEN)			
			Description	Kg	€	
S35A00013	C			Pair of skids	40	540
S75A00040	C			Pair of rear steering wheels	140	1.870
S21A00017	C	TT97 280		Rear roller Ø 220	115	1.660
S21A00018	C	TT97 300			135	1.710
S21A00019	C	TT97 320			135	1.790

HOT SELLING CONFIGURATIONS

STANDARD MACHINE CONFIGURATION WITH HAMMERS + DEPTH CONTROL			
Code A+B	Description	Kg	€
TCCN00002 + S35A00013	TT97 280 + Pair of skids	1090	11.810
TCCN00002 + S21A00017	TT97 280 + Rear roller	1165	12.930
TCCN00002 + S75A00040	TT97 280 + Pair of rear wheels	1190	13.140
TCCN00004 + S35A00013	TT97 300 + Pair of skids	1140	12.610
TCCN00004 + S21A00018	TT97 300 + Rear roller	1235	13.780
TCCN00004 + S75A00040	TT97 300 + Pair of rear wheels	1240	13.940
TCCN00006 + S35A00013	TT97 320 + Pair of skids	1190	14.330
TCCN00006 + S21A00019	TT97 320 + Rear roller	1285	15.580
TCCN00006 + S75A00040	TT97 320 + Pair of rear wheels	1290	15.660

STANDARD MACHINE CONFIGURATION WITH FLAILS + DEPTH CONTROL			
Code A+B	Description	Kg	€
TCCN00001 + S35A00013	TT97 280 + Pair of skids	1110	11.810
TCCN00001 + S21A00017	TT97 280 + Rear roller	1185	12.930
TCCN00001 + S75A00040	TT97 280 + Pair of rear wheels	1210	13.140
TCCN00003 + S35A00013	TT97 300 + Pair of skids	1110	12.610
TCCN00003 + S21A00018	TT97 300 + Rear roller	1185	13.780
TCCN00003 + S75A00040	TT97 300 + Pair of rear wheels	1210	13.940
TCCN00005 + S35A00013	TT97 320 + Pair of skids	1220	14.330
TCCN00005 + S21A00019	TT97 320 + Rear roller	1315	15.580
TCCN00005 + S75A00040	TT97 320 + Pair of rear wheels	1320	15.660

Voor eventuele opties - zie laatste pagina's

Optionals

The right accessory for every situation



Code	Classif.	Description	Mod.	Q.ty	Kg	€
S45A00094	-	Double Linkage kit for TR27F (allows rear mounting of the flail mower)	TR27F	x 1	50	570

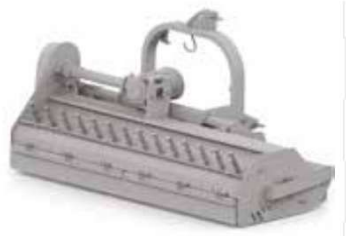

Code	Classif.	Description	Mod.	Q.ty	Kg	€	
S70A00038	C		Set of 10 rear rakes (complete with mud-scraper)	TR36 160	x 1	27	375
S70A00039			Set of 11 rear rakes (complete with mud-scraper)	TR36 180	x 1	32	400
S70A00040			Set of 12 rear rakes (complete with mud-scraper)	TR36 200	x 1	35	415
S70A00041			Set of 14 rear rakes (complete with mud-scraper)	TR36 220	x 1	40	485
S70A00042			Set of 15 rear rakes (complete with mud-scraper)	TR36 240	x 1	55	501
S70A00043			Set of 17 rear rakes (complete with mud-scraper)	TR56 280	x 1	58	576



Code	Classif.	Description	Mod.	Q.ty	Kg	€	
TCGA00120	C		Set of front protection chains	TR36 160	x 1	24	404
TCGA00121				TR36 180	x 1	27	445
TCGA00122				TR36 200	x 1	29	495
TCGA00123				TR36 220	x 1	32	540
TCGA00124				TR36 240	x 1	35	580
TCGA00125				TR56 280	x 1	40	660
SB1A00038				TT97 280	x 1	40	830
SB1A00039				TT97 300	x 1	42	880
SB1A00040				TT97 320	x 1	46	930



Code	Classif.	Description	Mod.	Q.ty	Kg	€	
S80A00078	C		Wearproof guard for frame (recommended on hammers version)	TT97 280	x 1	33	325
S80A00079				TT97 300	x 1	35	470
S80A00080				TT97 320	x 1	36	480

Optionals

The right accessory for every situation



Code	Classif.		Description	Mod.	Q.ty	Kg	€
S35A00023	-			TR27 / TR27F	x 1	-	102
S35A00019	-		Pair of skids	TR36 / TR36F	x 1	8	180
S35A00020	-			TR56 / TR56F	x 1	7	180



Code	Classif.		Description	Mod.	Q.ty	Kg	€
S80A00085				TT97 280	x 1	22	410
S80A00086	C		Set of counter-blades (valid for curved blades option)	TT97 300	x 1	24	415
S80A00087				TT97 320	x 1	25	438

Code	Classif.		Description	Mod.	Q.ty	Kg	€
SB1A00055	-		Additional transmission cover protection kit	TR56 / TR56F	x 1	-	61

Code	Classif.		Description	Mod.	Q.ty	Kg	€
Q25A00196	-		Transport frame up to 3 units	TR27 / TR36 / TR56	x 1	-	ON REQUEST

Op al onze aanbiedingen, op alle met ons afgesproken overeenkomsten en alle overeenkomsten die hiervan het gevolg kunnen zijn, zijn onze algemene verkoopvoorwaarden van toepassing. Deze zijn op uw verzoek aan u toe te zenden en zijn tevens te downloaden op www.farmstore.nl

KvK  84366788
BTW  NL863185277B01

IBAN  NL51 RABO 0375 0767 00
BIC  RABONL2U

SITE  www.farmstore.nl
EMAIL  info@farmstore.nl