

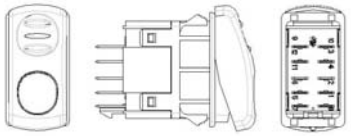

Models:
SELF-PROPELLED MODEL GREYHOUND - DOBERMANN

Bulletin Nr.
SO_0050





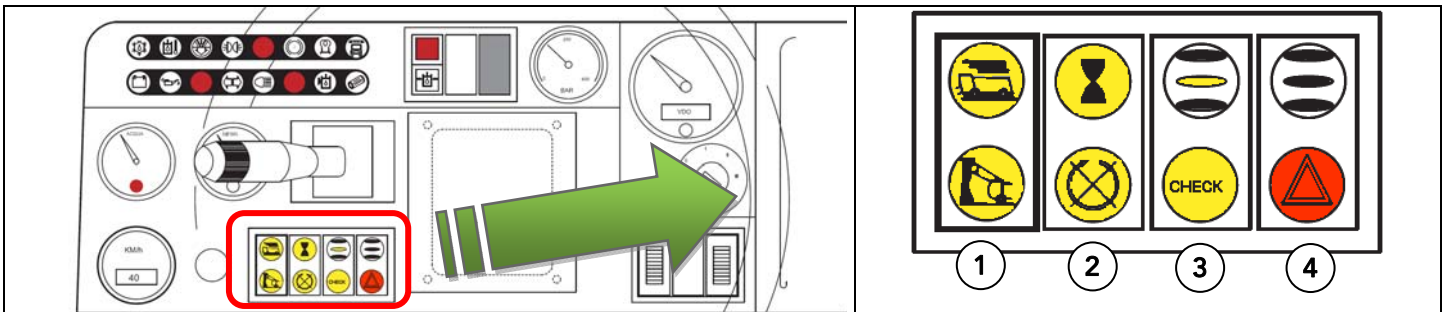

Date
01/04/2011

DASHBOARD: ROCKER SWITCHES AND CONTROLS (STAGE III A models)

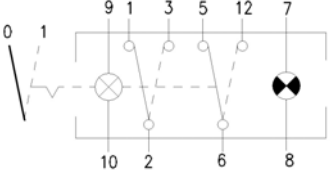
		12V – 0,4W 24V – 0,7W	Lamp "soft light"
		12V – 1,2W 24V – 1,2W	Lamp "standard light"

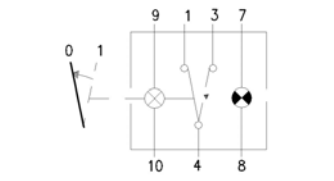
MAIN DASHBOARD

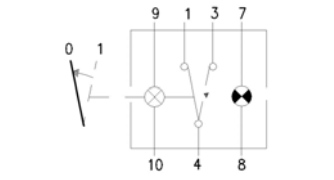





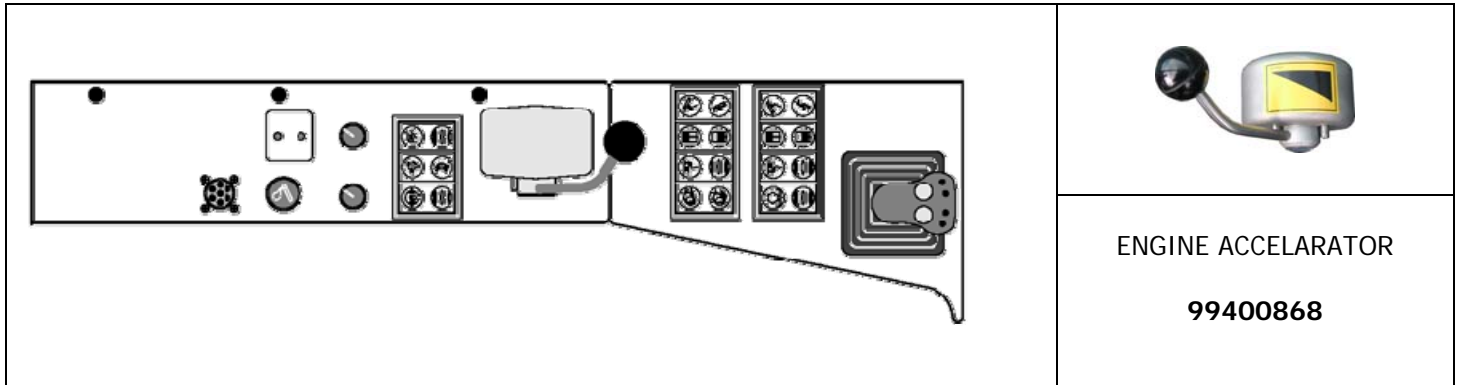



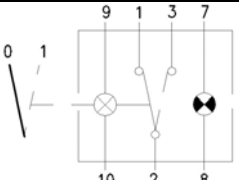

1		AUTOMOTIVE 99400906		SWITCH SOCKET (Ref. NOT FOR PARTS) 16.0691.0500.A3
2		ENGINE STOP DELAY 99400900		SWITCH SOCKET (Ref. NOT FOR PARTS) 17.0644.0500.A3
3		ENGINE CHECK-UP 99400898		SWITCH SOCKET (Ref. NOT FOR PARTS) 17.0644.0500.A3
4		HAZARD LIGHTS 99400905		SWITCH SOCKET (Ref. NOT FOR PARTS) 16.0677.0100.A4

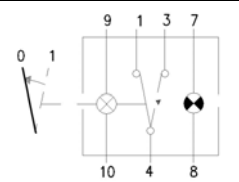

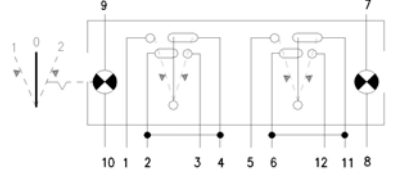

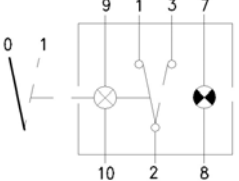

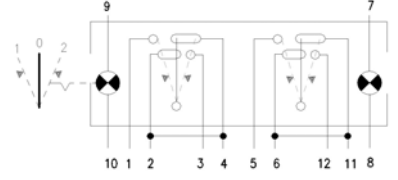

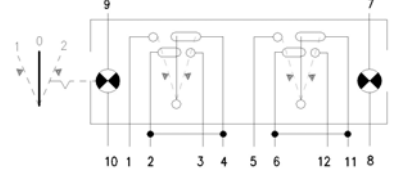

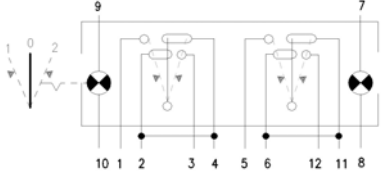

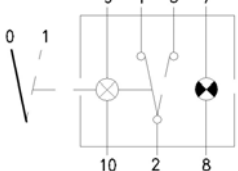

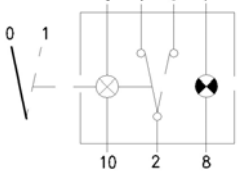
SIDE DASHBOARD

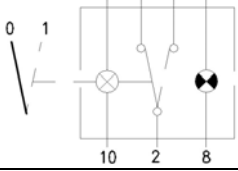

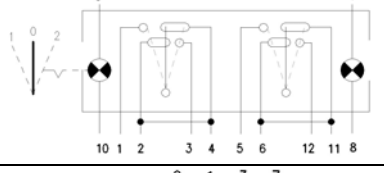

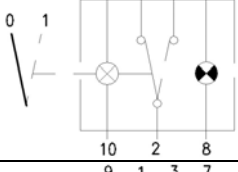

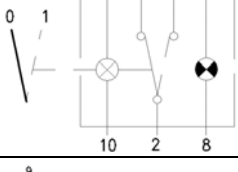

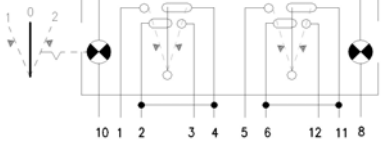
ENGINE ACCELARATOR

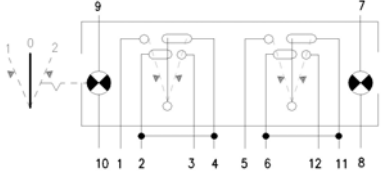
99400868

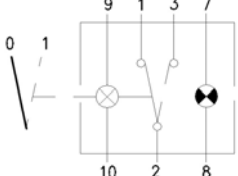
1		<p>CLUTCH</p> <p>99400888</p>		<p>SWITCH SOCKET</p> <p>(Ref. NOT FOR PARTS) 16.0694.0500.A3</p>
2		<p>DIFFERENTIAL GEARLOCK</p> <p>99400897</p>		<p>SWITCH SOCKET</p> <p>(Ref. NOT FOR PARTS) 17.0644.0500.A3</p>
3		<p>UNLOADING DOOR</p> <p>99400901</p>		<p>SWITCH SOCKET</p> <p>(Ref. NOT FOR PARTS) 17.0645.0700.A3</p>
4		<p>MILLING CUTTER BONNET</p> <p>99400889</p>		<p>SWITCH SOCKET</p> <p>(Ref. NOT FOR PARTS) 16.0694.0500.A3</p>
5		<p>COUNTER-KNIVES</p> <p>99400923</p>		<p>SWITCH SOCKET</p> <p>(Ref. NOT FOR PARTS) 17.0645.0700.A3</p>
6		<p>LATERAL CONVEYOR DISPLACEMENT</p> <p>99400922</p>		<p>SWITCH SOCKET</p> <p>(Ref. NOT FOR PARTS) 17.0645.0700.A3</p>

7		2 SPEED GEARBOX 99400924		SWITCH SOCKET (Ref. NOT FOR PARTS) 17.0645.0700.A3
8		I°-II° SPEED WHEEL MOTORS 99400890		SWITCH SOCKET (Ref. NOT FOR PARTS) 16.0694.0500.A3
9		UNLOADING EXTENSION WITH CONVEYOR LEFT 99400927		SWITCH SOCKET (Ref. NOT FOR PARTS) 16.0694.0500.A3
10		UNLOADING EXTENSION WITH CONVEYOR RIGHT 99400925		SWITCH SOCKET (Ref. NOT FOR PARTS) 16.0694.0500.A3
11		DOUBLE DISCHARGE CONVEYOR 99400951		SWITCH SOCKET (Ref. NOT FOR PARTS) 16.0695.0700.A3
12		UNLOADING BELT CONVEYOR LEFT 99400893		SWITCH SOCKET (Ref. NOT FOR PARTS) 16.0694.0500.A3
13		UNLOADING BELT CONVEYOR RIGHT 99400894		SWITCH SOCKET (Ref. NOT FOR PARTS) 16.0694.0500.A3
14		ADJUSTABLE DISCHARGE CONVEYOR LEFT 99400902		SWITCH SOCKET (Ref. NOT FOR PARTS) 17.0645.0700.A3

<p>15</p>		<p>ADJUSTABLE DISCHARGE CONVEYOR RIGHT 99400903</p>		<p>SWITCH SOCKET (Ref. NOT FOR PARTS) 17.0645.0700.A3</p>
<p>16</p>		<p>MOLASSE PUMP 99400896</p>		<p>SWITCH SOCKET (Ref. NOT FOR PARTS) 16.0694.0500.A3</p>
<p>17</p>		<p>UNLOADING DOOR – OPENING INDICATOR 99400848</p>		<p>UNLOADING DOOR POSITION SENSOR 99400815</p>
<p>18</p>		<p>UNLOADING BELT POTENTIOMETER WITH CABLE 99403104</p>		

UPSIDE CABIN CONTROLS

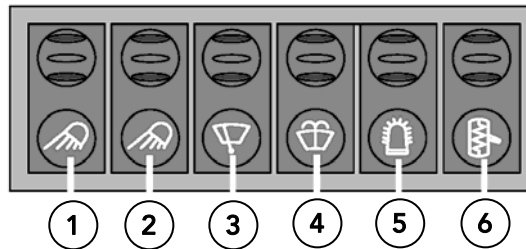

1		<p>FRONT WORKING LIGHTS</p> <p>99400892</p>		<p>SWITCH SOCKET</p> <p>(Ref. NOT FOR PARTS) 16.0694.0500.A3</p>
2		<p>REAR WORKING LIGHTS</p> <p>99400892</p>		<p>SWITCH SOCKET</p> <p>(Ref. NOT FOR PARTS) 16.0694.0500.A3</p>
3		<p>WINDSCREEN -WIPER</p> <p>99400904</p>		<p>SWITCH SOCKET</p> <p>(Ref. NOT FOR PARTS) 16.0692.0500.A3</p>
4		<p>WINDSHIELD-WIPER</p> <p>99400899</p>		<p>SWITCH SOCKET</p> <p>(Ref. NOT FOR PARTS) 17.0644.0500.A3</p>
5		<p>FLASHING LIGHT</p> <p>99400895</p>		<p>SWITCH SOCKET</p> <p>(Ref. NOT FOR PARTS) 16.0694.0500.A3</p>
6		<p>MIRROR HEATING</p> <p>99400891</p>		<p>SWITCH SOCKET</p> <p>(Ref. NOT FOR PARTS) 16.0694.0500.A3</p>