



*The effective technology*

# CATALOGUE OF SPARE PARTS

## MOUNTED COMPACTOMAT

### LK 300N

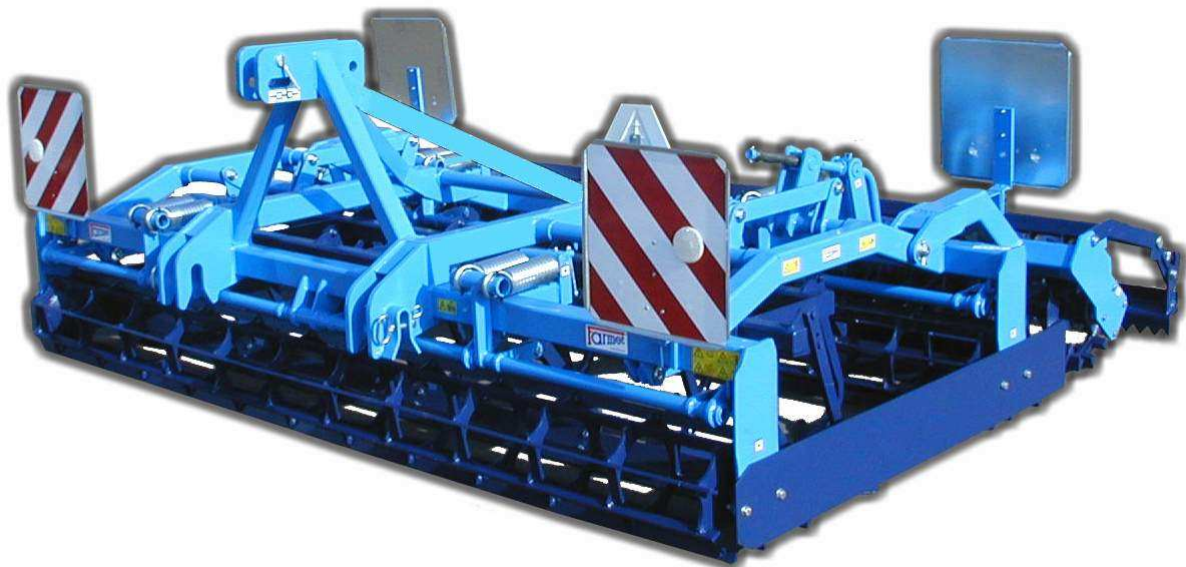

#### Farmet a.s.

Jiřinková 276  
552 03 Česká Skalice  
Czech Republic

Tel.: +420 491 450 140

+420 491 450 122

Fax: +420 491 450 136

E-mail: [farmet@farmet.cz](mailto:farmet@farmet.cz)  
[nd@farmet.cz](mailto:nd@farmet.cz)

http: [www.farmet.cz](http://www.farmet.cz)



Dear customer,

all spare parts that will be necessary for possible repairs of your machine shall be ordered using this catalogue.

The producer **is not responsible** for correct functionality and safety of the machine unless there only will be used **parts produced and approved by the company Farnet a.s. Česká Skalice.**

**☞☞ When ordering spare parts proceed please as follows:**

- A)** Specify the type and serial number of the machine (Tab. 1.)  
**B)** Specify the catalogue number of the part, its description and the desired quantity. (In case the part is divided to the left and right parts, specify this).

Tab. 1

<b>MACHINE TYPE</b>	
<b>MACHINE SERIAL NO.</b>	
<b>SPECIAL DESIGN OR ACCESSORIES</b>	
.....	
.....	
.....	
.....	
.....	

**Example of an order:**

**Machine:** LK 300N  
**Serial no.:** 2009/0125  
**Description of the part:** COMPACTOMAT SHARE  
**Catalogue no.:** 3000236  
**Quantity:** 13

- <b>CONTENTS</b>		page 3
- <b>LK 300N-2003</b>	<b>8000552</b>	page 4-6
- CROSSKILL ROLLER LK 300N-mount.	8000552-20001	page 7
- DRAG LK3-mount.	8000552-30002	page 8
- LK3 SHARE FRAME-mount.	8000552-30004	page 8-9
- SPRING LK4-mount.	8000549-40062	page 9
- REAR DISCS I. L+R- pos. holder	3001110	page 10
- FRONT DISCS L+R-mount.	3001298	page 10-11

# 8000552 COMPACTOMAT LK 300N - 2003

Pos./Catalogue no.	Description of the part	Standard	Quantity
1	8000552-10001	FRAME LK3N 2003 - weld. set	pc 1
2	8000552-30004	LK3 SHARE FRAME mount.	pc 1
3	8000552-20001	CROSSKILL ROLLER LK300N-mount.	pc 1
4	8000552-30002	DRAG LK3 mount.	pcs 4
5	8000552-30006	ROLLER LK3	pcs 2
7	8000549-40058	ATTACHMENT BAR LK4	pc 1
8	8000549-40060	SLIDING FRAME PULL ROD LK4 weld. set	pcs 2
9	8000549-40061	PULL ROD L=150 LK4	pcs 4
10	8000549-40062	SPRING LK4 - mount.	pcs 8
11	8000549-40063	SPRING HOLDER LK4 weld.	pcs 4
12	8000549-40066	COVERING PLATE P LK4	pcs 2
13	6535	BEARING UCFL 207	pcs 4
14	4002454	SUSPENSION PIN K2-3N- weld.	pcs 2
15	8000549-40067	WINCH M8/130	pcs 4
16	4000038	THIRD-POINT PIN I. (welded)	pc 1
17	4000161	PIN dia.25h11x90- weld.	pcs 4
18	8000549-40068	PULL ROD LK L=430	pcs 2
19	4000164	PIN dia.30h11x152- QUENCHED	pcs 2
20	8000549-40070	ROLLER PIN LK- weld.	pcs 2
36	9001503	TR KR 25x4-35	pcs 12
39	4000250	SAFETY CRANK RING	pc 1
40	4001533	CRANK HANDLE	pc 1
42	3001110	REAR DISCS LL+R- pos. holder	pcs 1 + 1
43	3001298	FRONT DISCS L+R- pos. holder	pcs 1 + 1
44	3001210	TRIANGLE SHIELD WITH HOLDER	pc 1
46	2505	PIN WITH RING dia.40	pc 1
47	4406	STICKER MAX. SPEED 20	pc 1
48	2579	ORANGE REFLECTING STICKER	pcs 2
49	2470	SAFETY SPLIT PIN dia.4.5/dia.36	pcs 2
60	6675	SILENBLOK 70x70	21124.091L pcs 2
71	4343	SCREW M 12/35	ČSN 02 1101.25 pcs 16
72	3339	SCREW M 12/50	ČSN 02 1101.55 pcs 8
78	1129	SCREW M 16/40	ČSN 02 1103.55 pcs 8
79	0619	SCREW M 16/60	ČSN 02 1101.55 pcs 12
85	4503	NUT M 8	4SN 02 1492.55 self-locking pcs 8
86	5694	NUT M 12 with collar	DIN 6923 pcs 24
87	3683	NUT M 16 - DIN 985	ČSN 02 1492.55 pcs 12
88	4301	NUT M 12	ČSN 02 1492.55 self-locking pcs 4
101	1214	WASHER 13	ČSN 02 1702.15 pcs 4
102	1219	WASHER B17 DIN 125 T1	ČSN 02 1702.15 pcs 8
103	5651	WASHER 18-into hard wood	ČSN 02 1729.05 pcs 24
104	1223	WASHER 26	ČSN 02 1702.15 pcs 5
105	2866	WASHER 31	ČSN 02 1702.15 pcs 6

<b>Pos./Catalogue no.</b>	<b>Description of the part</b>	<b>Standard</b>	<b>Quantity</b>	
106	2157	WASHER 16	ČSN 02 1740.05	pcs 8
119	6674	FLEXIBLE PIN-8x80	ISO 8752	pcs 8
120	1659	SPLIT PIN 4/36	ČSN 02 1781.05	ps 1
121	1183	SPLIT PIN 6,3/40	ČSN 02 1781.05	pcs 4
122	6561	SECURING RING 20 – wire	ČSN 02 2925.2 POZINK	pc 1
123	1185	SPLIT PIN 8/50	ČSN 02 1781.05	pcs 6
135	1725	HEAD KM6	CSN 027421.5	pcs 6
140	4359	STICKER P 1 H		pcs 2
141	4366	STICKER P 2 H		pcs 2
142	4361	STICKER P 4 H		pcs 2
143	4360	STICKER P 6 H		pcs 2
144	4365	STICKER P 37 H		pcs 6
145	4369	STICKER P 53 H		pcs 4
146	3320	STICKER LUBRICATION POINT		pcs 12
147	3316	STICKER ATTACHMENT POINT		pcs 4
148	3315	STICKER CLIMBING ABILITY 11		pcs 2
150	4357	STICKER FARMET 55/135		pcs 4
151	4358	STICKER FARMET 30/70		pcs 4

8000552 COMPACTOMAT LK 300N-2003

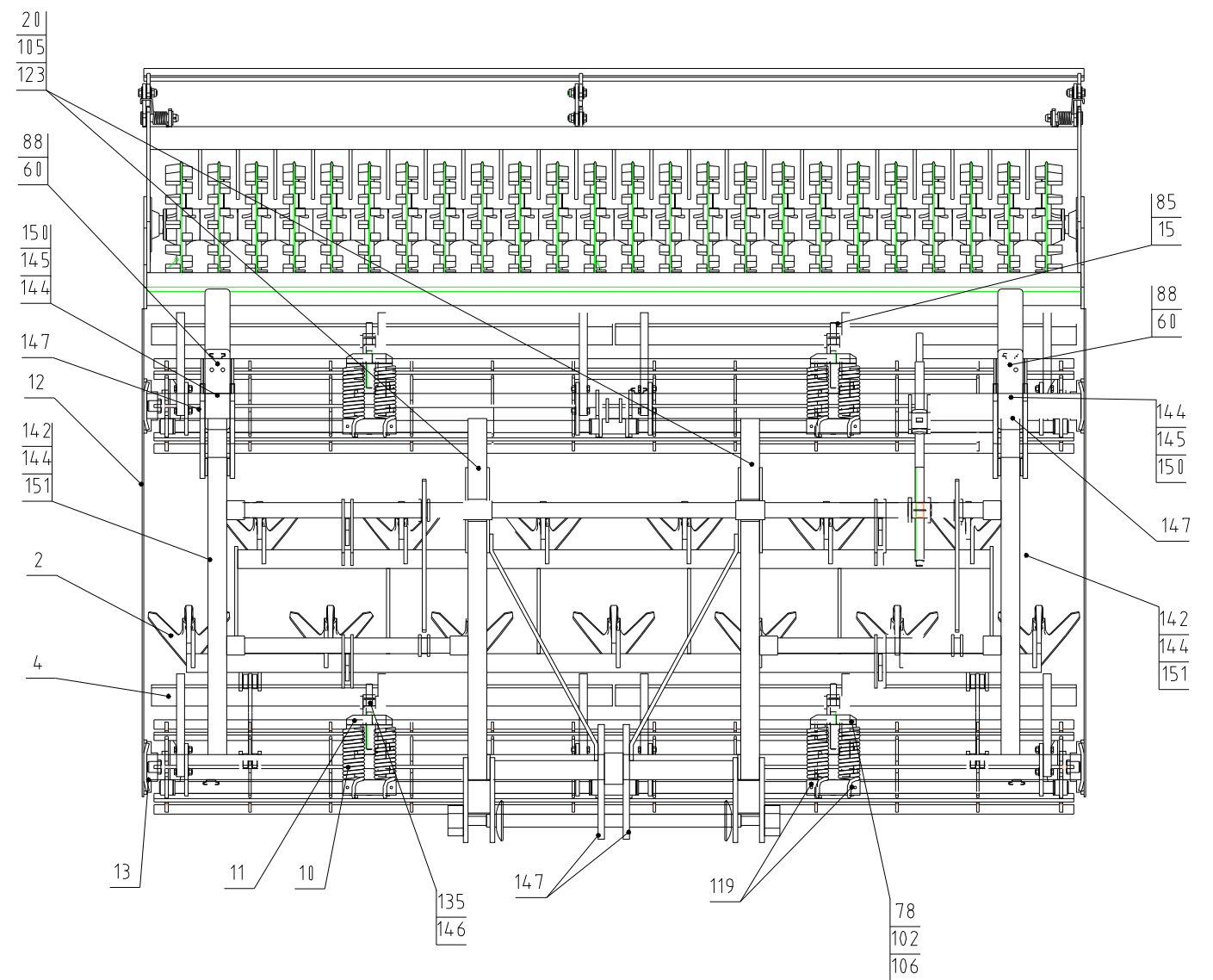
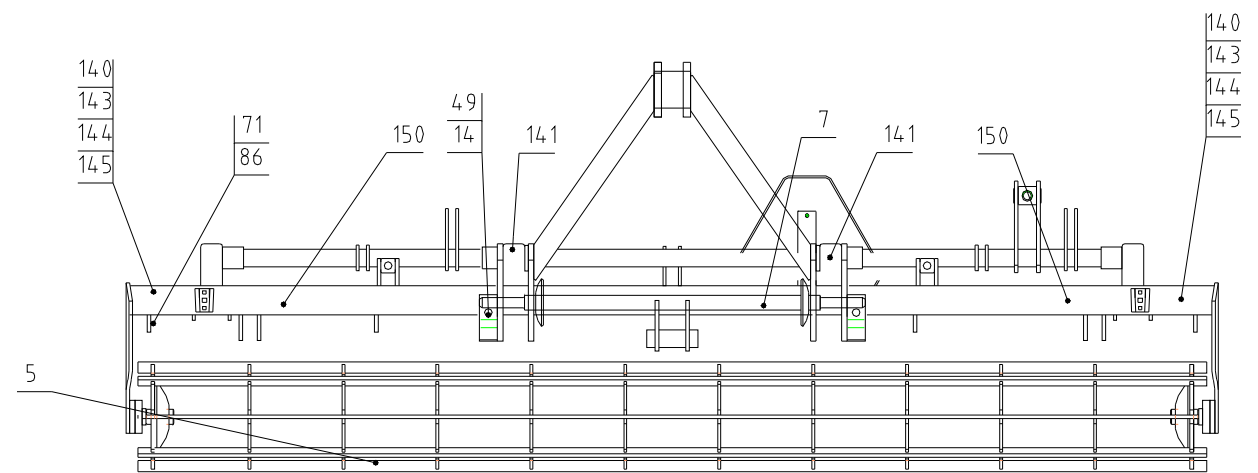
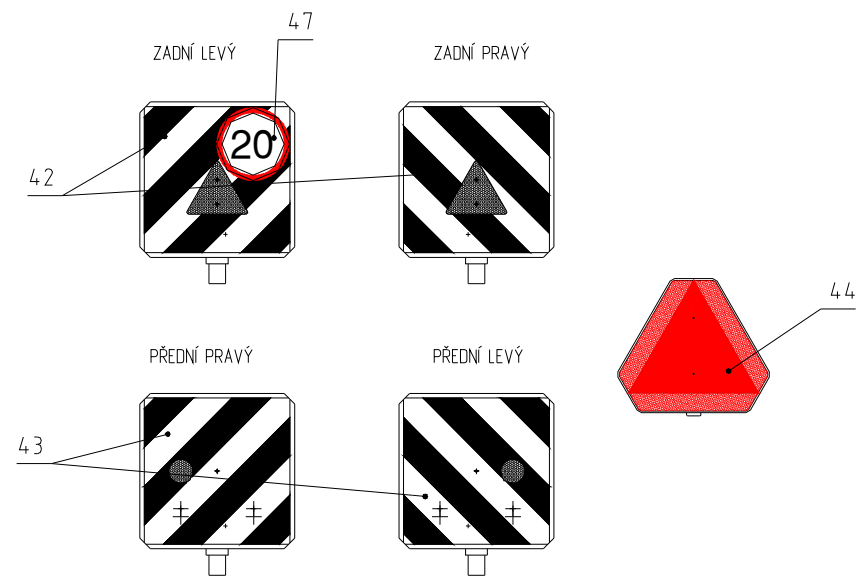
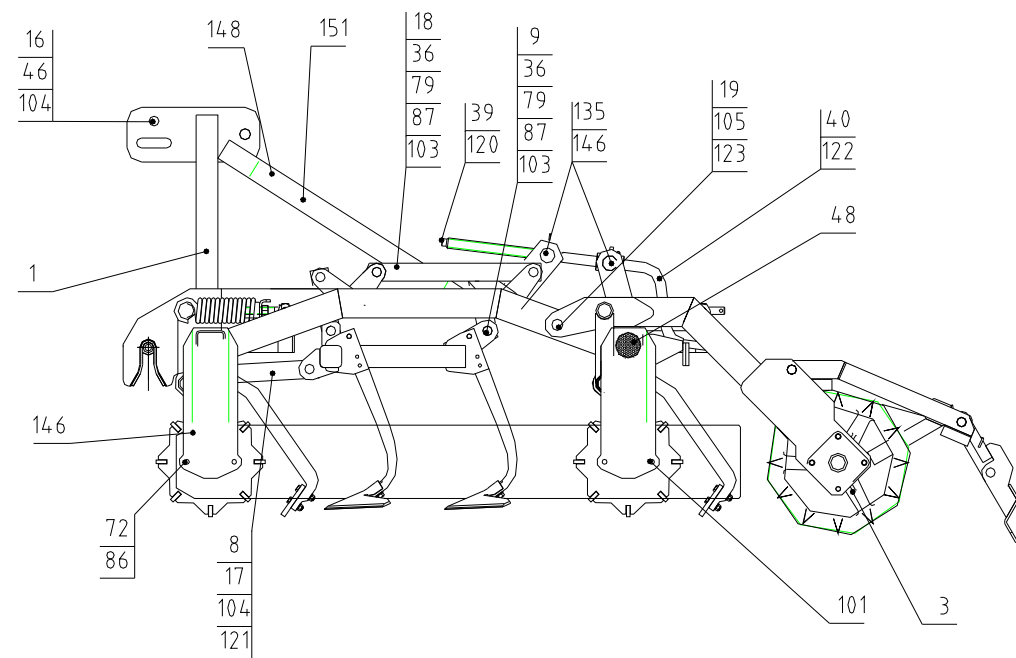

# 8000552-20001 CR. ROLLER LK 300N-mount.

Pos./Catalogue no.	Description of the part	Standard	Quantity	
1	8000552-30007	FRAME CR.ROLLER LK3- weld.	pc 1	
2	3000155	CROSSKILL WHEEL 400 / 120mm	pcs 22	
3	4001718	SIDE WHEEL 107,5mm	pcs 2	
4	8000552-30009	SHAFT WITH PINS 2975- weld.	pc 1	
5	4000097	RING	pcs 2	
6	8000552-30008	CLEANER CROSSKILL LK3- weld.	pc 1	
7	4002269	DRAG PULL ROD CR.-weld.	pcs 3	
8	3001688	REAR DRAG 3m-weld.	pc 1	
9	4002265	SEATING INSERT L=25	pcs 4	
10	4002503	PIN 25x112 in diameter with a head	pcs 2	
11	5677	LOWER DRAG SPRING L	pc 1	
12	5678	LOWER DRAG SPRING R	pc 1	
13	4002504	FRICITION RING dia.40/dia.26	pcs 6	
14	4000411	BEARING LEF ( UCF ) 208	pcs 2	
15	8000549-40065	SEATING INSERT L=22	pcs 2	
53	1183	SPLIT PIN 6,3/40	ČSN 02 1781.05	pcs 2
54	4355	SCREW M 16/50	ČSN 02 1101.55	pcs 6
55	3683	NUT M 16 - DIN 985	ČSN 02 1492.55	pcs 6
56	5651	WASHER 18-into hard wood	ČSN 02 1729.05	pcs 12
57	3718	WASHER 25	ČSN 02 1702.15	pcs 2
58	3926	SCREW M 12/40	ČSN 02 1101.55	pcs 8
59	5694	NUT M 16 with collar	DIN 6923	pcs 8

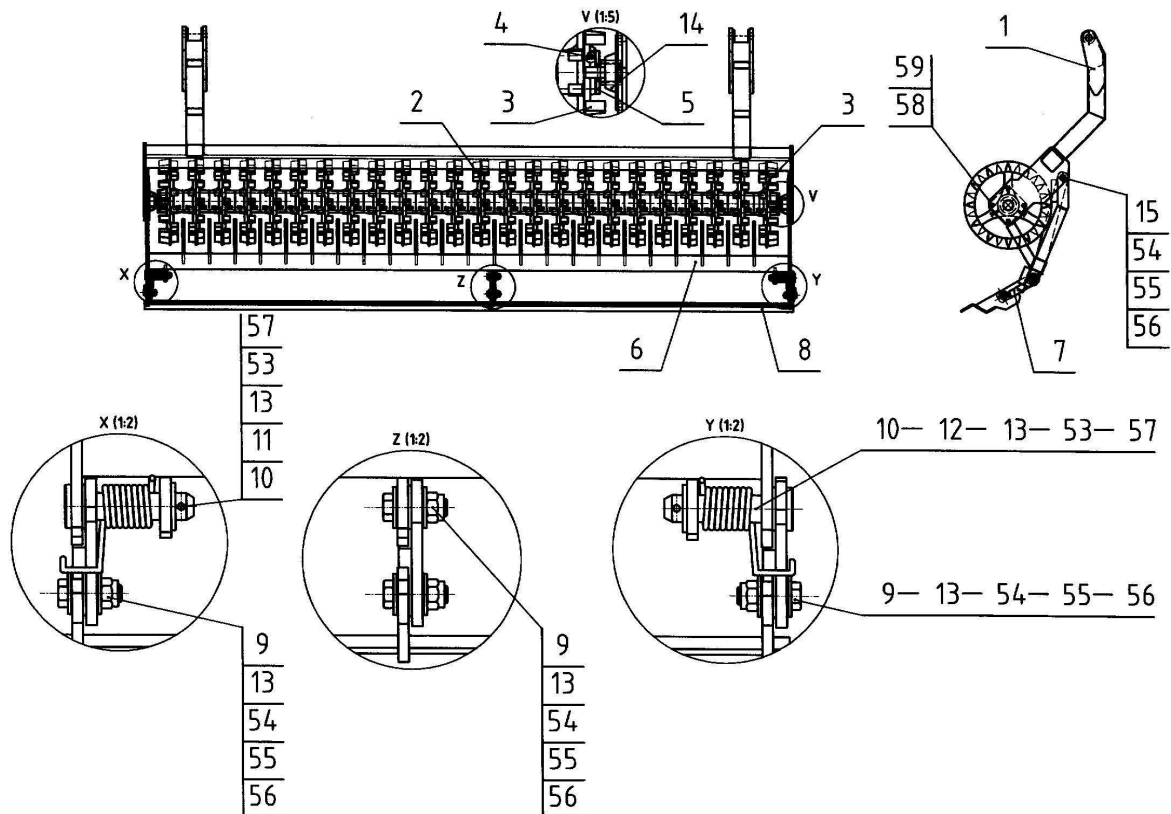

## 8000552-30002 DRAG LK3-mount.

Pos./Catalogue no.	Description of the part	Standard	Quantity	
1	8000552-30003	DRAG TUBE LK3 weld.	pc 1	
2	8000549-30009	DRAG FROG LK4	pcs 3	
3	8000552-40002	DRAG BAR LK3	pc 1	
4	8000549-40043	TUBE HOLDER LK4 weld.	pc 1	
5	1111	SCREW M 10/40	ČSN 02 1303.55	pcs 3
6	1114	SCREW M 10/50	ČSN 02 1103.55	pcs 3
7	4412	SCREW M 12/55	ČSN 02 1101.55	pcs 6
10	5693	NUT M 10 with collar	DIN 6923	pcs 6
11	5694	NUT M 12 with collar	DIN 6923	pcs 6

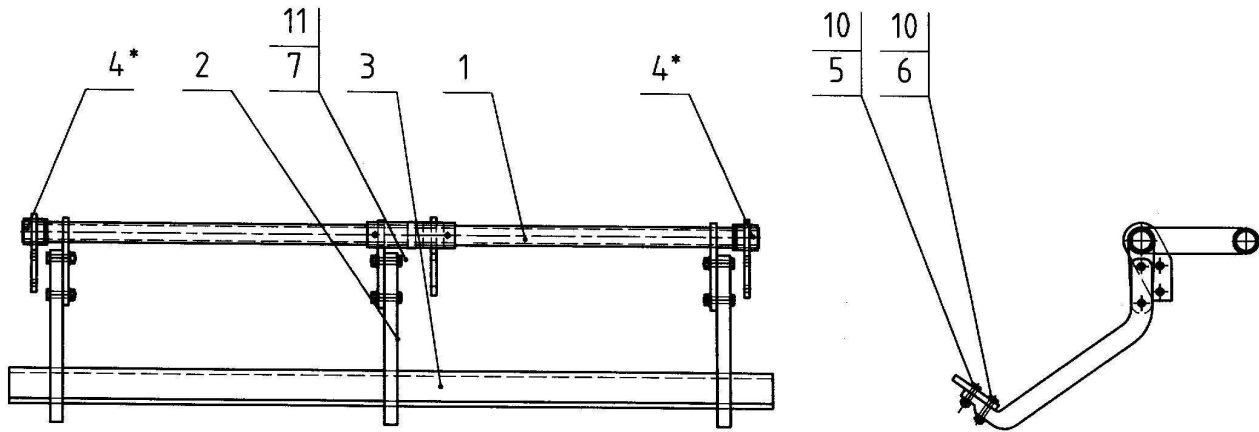

## 8000552-30004 SHARE FRAME LK3-mount.

Pos./Catalogue no.	Description of the part	Standard	Quantity	
1	8000552-30005	SLIDING FRAME LK3 weld.	pc 1	
3	6132	SHEAR FROG FARMET	4002734	pcs 13
4	3000236	COMPACTOMAT SHARE		pcs 13
5	2490	SCREW M 12/50	ČSN 02 1326.55	pcs 13
6	6077	SCREW M 12/45	ČSN 02 1101.55	pcs 13
7	6246	SCREW M 10/40 5S	ČSN 02 1101.25	pcs 13
8	5693	NUT M 10 with collar	DIN 6923	pcs 13
9	5694	NUT M 12 with collar	DIN 6923	pcs 26



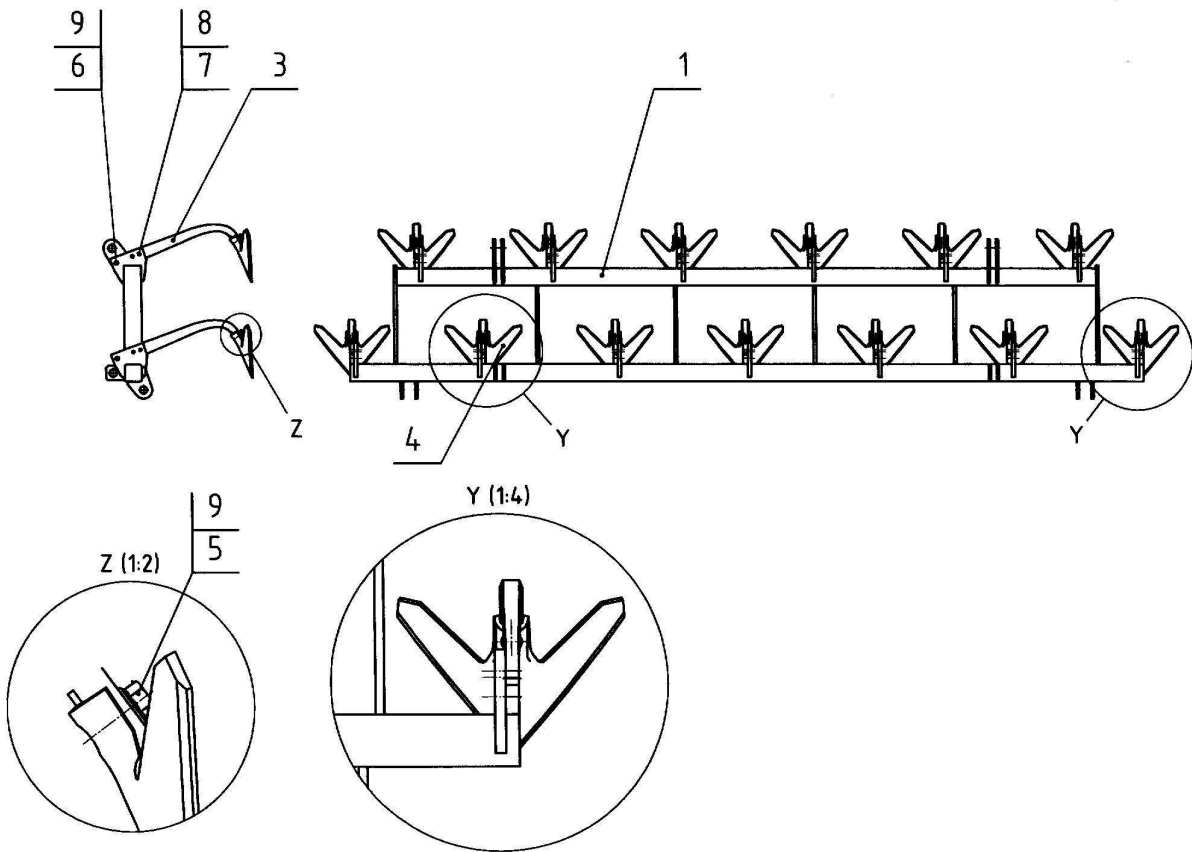

### 8000549-40062 SPRING LK4-mount.

Pos./Catalogue no.	Description of the part	Standard	Quantity
1 6329	TENSION SPRING DIA.70/11/265	1 TOW END	pc 1
2 4002544	TOW-SPRING NUT		pc 1

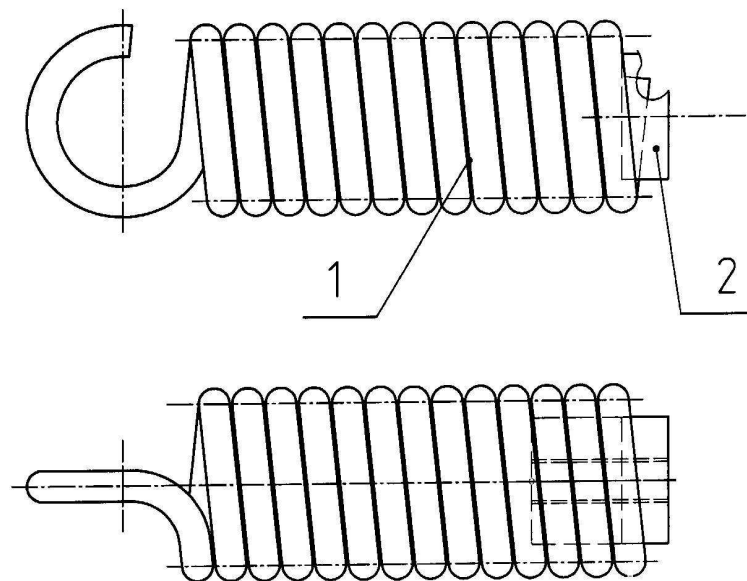

## 3001110 REAR DISCS I. L+R- pos. holder

Pos./Catalogue no.	Description of the part	Standard	Quantity	
1	4001392	SHIELD HOLDER L+R II.-weld.	pc 1	
2	4002752	SAFETY SHIELD, SHEET-mount.	pc 1	
3	2497	TRIANGLE REFLECTING PLATE	pc 1	
4	2531	SCREW M 5/25	CSN 021151.00	pcs 2
5	6236	M5 NUT – (lock nut)	CSN 021492	pcs 2
6	4164	WASHER 5.1	CSN021702.05	pcs 2

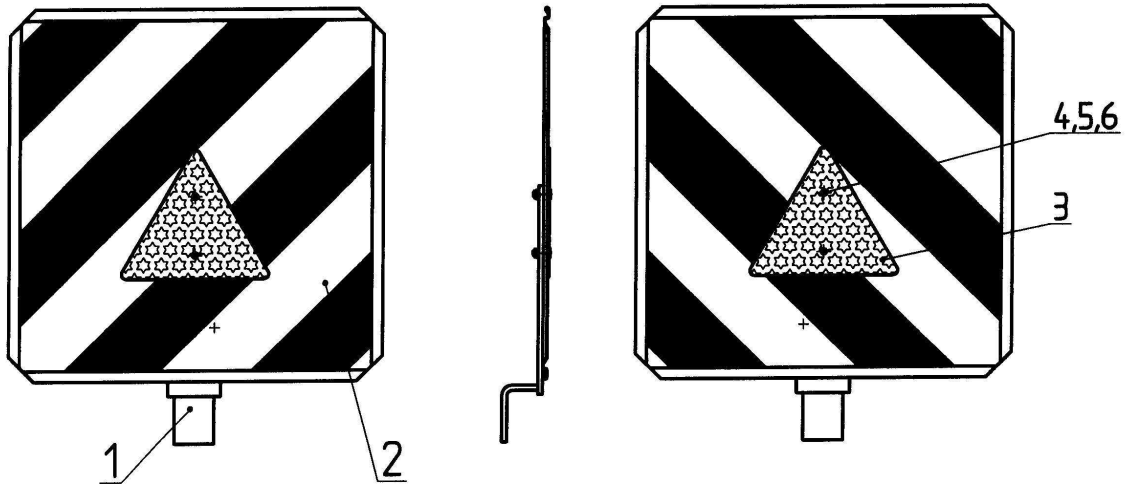

## 3001298 FRONT DISCS L+R-mount.

Pos./Catalogue no.	Description of the part	Standard	Quantity	
1	4001392	SHIELD HOLDER L+R II.-weld.	pc 1	
2	4002752	SAFETY SHIELD, SHEET-mount.	pc 1	
3	2498	WHITE REFLECTING STICKER	pc 1	
4	5559	SCREW M 5/14 - (countersink)	CSN021155.25	pcs 4
5	6236	NUT M 5 - (lock nut)	CSN 021492	pcs 4

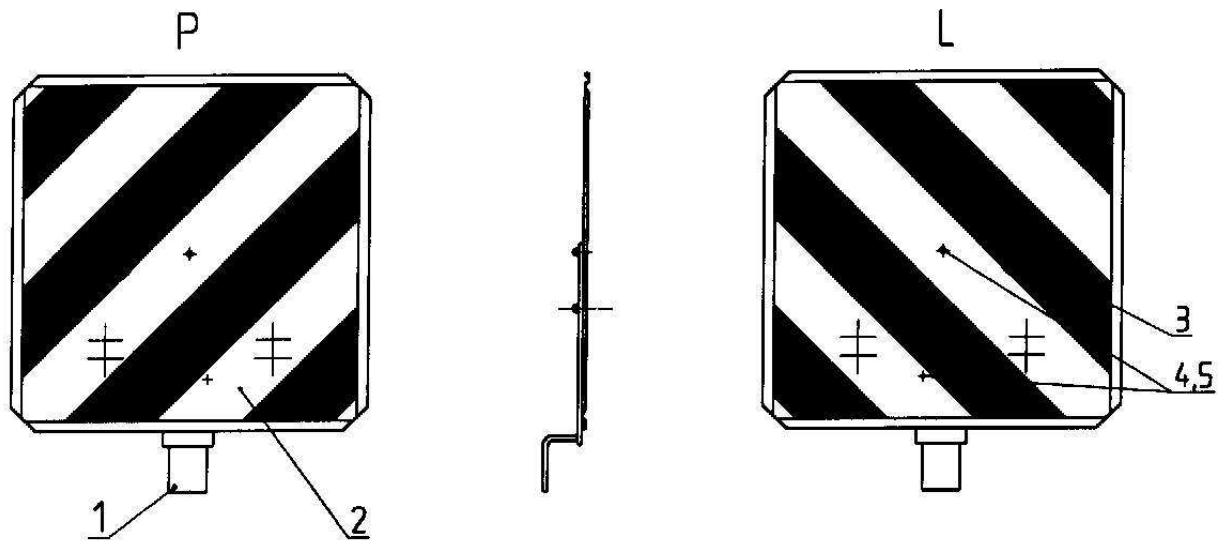

Issued by: Technical Department, Farnet a.s., Jiřinková 276, 552 03 Česká Skalice, on 25.02.2009,  
total number of pages: 11, changes reserved.