



The effective technology

OPERATING MANUAL

MOUNTED UNFOLDING KOMPAKTOMAT

K400NS

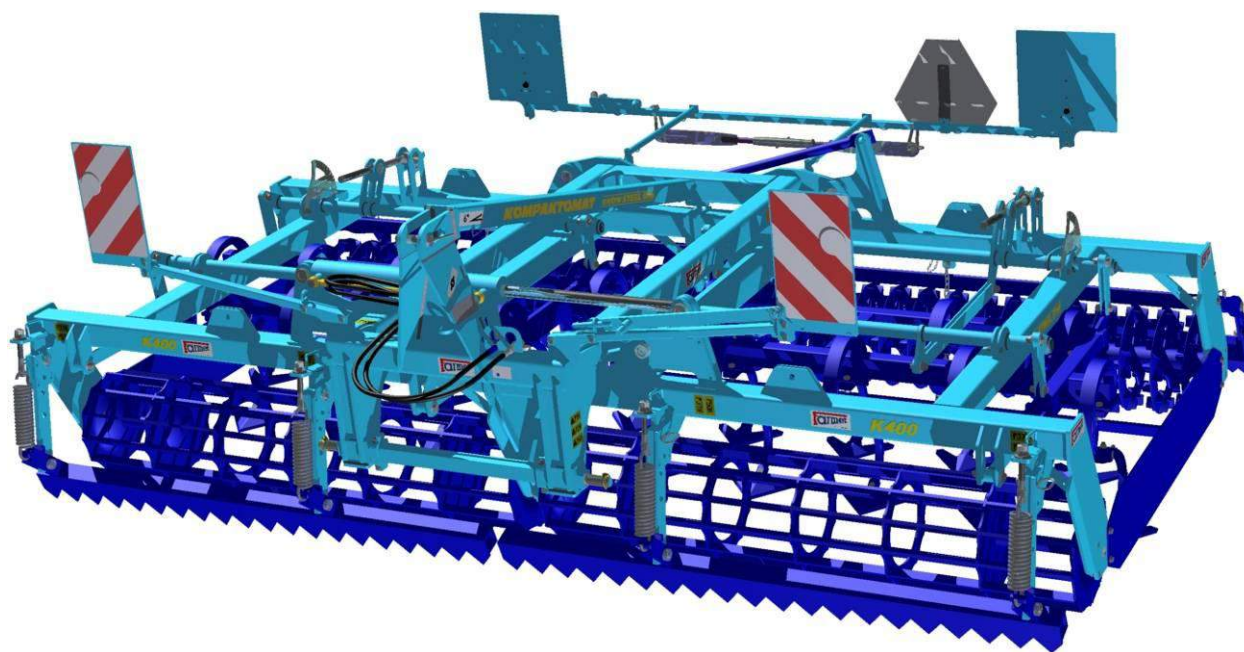

Farmet a.s.

Jiřinková 276
552 03 Česká Skalice
Czech Republic

Tel: 00420 491 450 140

00420 491 450 122

Fax: 00420 491 450 136

E-mail: farmet@farmet.cz

obchod@farmet.cz

[http: www.farmet.cz](http://www.farmet.cz)



Dear Customer,

The **K Series** Mounted Kompaktomats are quality products by Farnet a.s., Česká Skalice, Czech Republic. The advantages of your machine can be fully utilized after studying this Operating manual.

The serial number of the machine is stamped on the production label and mentioned in the Operating manual (see Tab. 1). This serial number should be mentioned for reference when ordering spare parts. The production label is located on the central frame near the shaft.

All spare parts should be ordered according to the official *Spare Part Catalogue* issued by Farnet a.s., Česká Skalice, Czech Republic.

The Use of Your machine

The Kompaktomat is designed for soil preparation before sowing and for follow-up operations after ploughing or stubble ploughing. Use the machine with the tractors the output of which is 80 to 120 kW. For the optimum soil cultivation keep the working speed between 8 to 12 km p.h.

Production label for **KOMPAKTOMAT K400NS**



Chart 1- Characteristics of the machine

TYPE OF MACHINE *	K400NS I.A	K400NS I.B	K400NS II.A	K400NS II.B
SERIAL NUMBER OF MACHINE				
SPECIAL VERSION OR ACCESSORIES:				
.....				
.....				
.....				
.....				
.....				

- CONTENTS	Page 3
- CRITICAL PARAMETERS	Page 4
TECHNICAL PARAMETERS	Page 4
SAFETY WARNING	Page 4
- A. GENERAL INSTRUCTIONS FOR USE	Page 4-5
PROTECTIVE EQUIPMENT	Page 5
- B. TRANSPORTING THE MACHINE BY VEHICLES	Page 6
- C. MANIPULATING THE MACHINE BY LIFTING EQUIPMENT	Page 6
- D. WORK SAFETY LABELS	Page 6-8
- 1. DESCRIPTION OF THE MACHINE	Page 9
1.1 WORKING PARTS OF THE MACHINE	Page 9
1.2 HYDRAULICS	Page 10
- 2. ASSEMBLY OF THE MACHINE AT THE CUSTOMER'S SITE	Page 10
- 3. PUTTING INTO OPERATION	Page 10
3.1 AGGREGATION TO THE TRACTOR	Page 11
3.2 CONNECTING THE HYDRAULICS	Page 11
3.3 FOLDING AND UNFOLDING OF THE MACHINE	Page 12-14
- 4. TRANSPORTING THE MACHINE ON GROUND COMMUNICATIONS	Page 14
- 5. ADJUSTING THE WORKING PARTS OF THE MACHINE	Page 15
5.1 ADJUSTING THE SPRING-MOUNTED FRONT LEVELLER	Page 15
5.2 ADJUSTING THE DEPTH OF THE SHARE SECTION	Page 16
5.3 ADJUSTING THE LEVELLER HEIGHT BEHIND SHARES	Page 16-17
- 6. MAINTENANCE AND REPAIRS	Page 17
6.1 LUBRICATION PLAN FOR THE MACHINE	Page 17-18
6.2 REPLACEMENT OF WORN-AND-TORN SHARES	Page 18-19
- 7. STORING THE MACHINE	Page 20
- 8. ENVIRONMENTAL PROTECTION	Page 20
- 9. MACHINE DISPOSAL AFTER ITS SERVICE LIFE	Page 20
- 10. SERVICES AND WARRANTY CONDITIONS	Page 20-21
- LETTER OF GUARANTEE	Page 22
- CE CERTIFICATE OF CONFORMITY	

CRITICAL PARAMETERS OF THE MACHINE

- ^(x) The machine is to be used for presowing preparation of soil after ploughing or stubble breaking with working depth from 0 mm to 100 mm for soil cultivation in agriculture. Other uses exceeding the determined purpose are considered unauthorized.
- ^(x) The machine is operated by the tractor operator.
- ^(x) The operator must not use the machine for other purposes, particularly:
 - ^(x) For transporting people on the construction of the machine.
 - ^(x) For transporting load on the construction of the machine.
 - ^(x) Aggregation of the machine with other tractive equipment than stated in Chapter “3.1/p.11”.



TECHNICAL PARAMETERS

Chart 2 – Technical parameters K400NS

PARAMETERS	K400NS
Working width (mm)	4000
Transport width (mm)	3000
Transport height (mm)	2670
Total length of the machine (mm)	2860
Working depth (mm)	0-100
Number of shares ARROW/CHISEL	18/39
Working capacity (ha/h)	3-4
Working speed (km/h)	8-12
Maximum transport speed (km/h)	20
Maximum slope accessibility (°)	6
Max. weight of the machine (ver. II)	2670

For parameters of the recommended pulling instrument (tractor) see Chapter 3.1, Tab. 4/p. 11.

SAFETY WARNING

	This warning symbol warns against an imminent dangerous situation that could lead to death or serious injury.
	This warning symbol warns against a dangerous situation that could lead to death or serious injury.
	This warning symbol warns against a situation that could lead to a small or minor injury. It also points out dangerous tasks related to the activity that could lead to an injury.

A. GENERAL INSTRUCTIONS FOR USE

- A.1** ^(x) The machine is produced in compliance with the latest technological conditions and approved safety regulations. However, the use of the machine may still cause injuries to the user or third persons or damage to the machine or occurrence of other material damages.
- A.2** ^(xx) Use the machine only in a technically unexceptionable condition, in compliance with its purpose, with awareness of potential risks and observance of safety instructions stated in this manual! Immediately eliminate all defects that could have a negative impact on safety!

A.3 ⁽⁷⁾ The machine may only be operated by a person authorized by the owner under the following conditions:

- ⁽⁸⁾ He or she must have a valid driving licence in the relevant category,
- ⁽⁹⁾ He or she must be verifiably informed on the safety rules of working with the machine and must have command of the operation of the machine in practice,
- ⁽¹⁰⁾ The machine must not be operated by a minor (minors),
- ⁽¹¹⁾ He or she must understand the meaning of warning symbols placed on the machine. Respecting the symbols is important for a safe and reliable operation of the machine.

A.4 ⁽¹²⁾ Maintenance and service repairs may only be performed by a person:

- ⁽¹³⁾ Authorized by the owner,
- ⁽¹⁴⁾ Trained in an engineering field with the knowledge of repairs of similar machinery,
- ⁽¹⁵⁾ Verifiably informed on the safety rules of working with the machine,
- ⁽¹⁶⁾ With a driving licence in the relevant category for repairs of the machine attached to a tractor.

A.5 ⁽¹⁷⁾ The operator of the machine must ensure safety of other people during the work with the machine and its transportation.

A.6 ⁽¹⁸⁾ The operator should not be on the construction of the machine during the work in the field or during the transportation ⇒ the operator must control the machine from the tractor cabin.



A.7 ⁽¹⁹⁾ The operator may only enter the construction of the machine when the machine is off and secured against movement only in order to:

- ⁽²⁰⁾ adjust the working parts of the machine,
- ⁽²¹⁾ repair and maintain the machine,
- ⁽²⁹⁾ release or secure the ball valves of the axle,
- ⁽²⁷⁾ secure the ball valves of the axle before tilting the side frame,
- ⁽²⁸⁾ adjust the working parts of the machine after opening the side frame.



A.8 ^(xxx) When climbing onto the machine, do not step on the tyres of the rolls or other revolving parts as they may roll over and you can seriously hurt yourself if you fall down.



A.9 ⁽²²⁾ Any changes or adjustments of the machine may only be performed with a written consent of the producer. The producer is not responsible for any potential damages occurred as a result of non-compliance with this instruction. The machine must always be equipped with the prescribed accessories, equipment and gear including the safety labels. All warning and safety signs must be always legible and at their positions. They must be replaced if damaged or lost without delay.

A.10 ⁽²³⁾ The operating manual and the requirements of the safety at work must be always available to the operator.



A.11 ⁽²⁴⁾ When operating the machine, the operator must not consume alcohol, medicine, narcotic and hallucinogenic substances that reduce attention and coordination abilities. If the operator has to take medicine prescribed by the physician or if he or she uses over the counter medicine, he or she must be informed by the physician whether he or she is able to reliably and safely operate the machine under these circumstances.



PROTECTIVE EQUIPMENT

In order to operate and maintain the machine, you need:

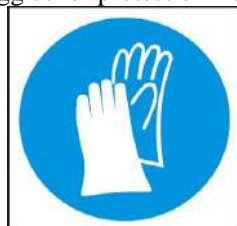

- Close-fitting clothing
- Protective gloves and goggles for protection from dust and sharp parts of the machine



B. TRANSPORTING THE MACHINE BY VEHICLES

- B.1** ⁽¹⁾ The vehicle intended for the transportation of the machine must have at least the same bearing capacity as the weight of the transported machine is. The total weight of the machine is stated on the production label.
- B.2** ⁽²⁾ The dimensions of the transported machine including the vehicle must comply with valid regulations for traffic on ground communications (decrees, acts).
-  **B.3** ⁽³⁾ The transported machine must be always attached to the vehicle so that it cannot be released during transportation.
- B.4** ⁽⁴⁾ The carrier is responsible for damages caused by the release of incorrectly or insufficiently attached machine to the vehicle.

C. MANIPULATING THE MACHINE BY LIFTING EQUIPMENT

- C.1** ⁽¹⁾ The lifting equipment and binding instruments intended for manipulation with the machine must have at least the same bearing capacity as the weight of the manipulated machine is.
-  **C.2** ⁽²⁾ The machine may only be attached for manipulation in designated places marked by stick-on labels showing a "chain". 
- C.3** ⁽³⁾ When attached (suspended) in designated places, it is not allowed to move in the area of potential reach of the manipulated machine.

D. WORK SAFETY LABELS

Warning safety labels are used for the protection of the operator.

THE FOLLOWING APPLIES GENERALLY:

- D.1** Strictly observe the warning safety labels.
- D.2** All safety instructions also apply to other users.
- D.3** If the aforementioned "SAFETY LABEL" located on the machine is damaged or destroyed, **THE OPERATOR MUST REPLACE IT WITH A NEW ONE!!!**

The position, appearance and exact meaning of work safety labels on the machine are given in the following charts (Chart 3/p.6-7) and the pictures (Picture 1/p.8).

Chart 3 – Stick-on warning safety labels placed on the machine

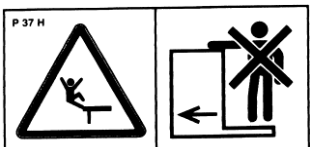
WARNING SAFETY LABEL	TEXT TO THE LABEL	POSITION ON THE MACHINE
	<p>Read carefully the operating manual before manipulation with the machine. Observe the instructions and safety rules when operating the machine.</p>	<p>P 1 H</p>
	<p>Driving the machine and transportation on its construction is strictly forbidden.</p>	<p>P 37 H</p>

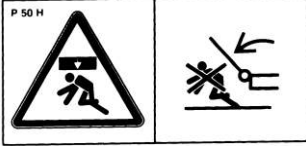
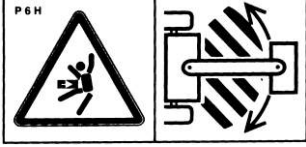
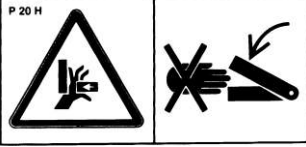
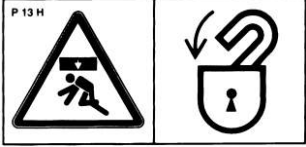
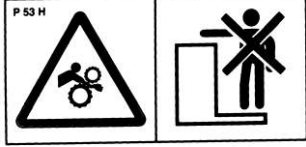
	<p>When connecting and disconnecting, do not enter the area between the tractor and the machine. Do not enter that area unless the tractor and the machine are not moving and the engine is off.</p>	<p>P 2 H</p>
	<p>When opening and closing the side frames and service bridge, stay beyond their reach.</p>	<p>P 50 H</p>
	<p>Stay beyond reach of the set Tractor – Agricultural Machine when the tractor engine is running.</p>	<p>P 6 H</p>
	<p>When unfolding the side frames into the transport position, do not reach into the area of contact with the central frame.</p>	<p>P 20 H</p>
	<p>Secure the axle of the machine against an unexpected drop before its transportation.</p>	<p>P 13 H</p>
	<p>Do not approach the rotary parts of the machine unless they are standing still, i.e. they are not rotating.</p>	<p>P 53 H</p>

Picture 1 – Warning labels on the machine K400NS

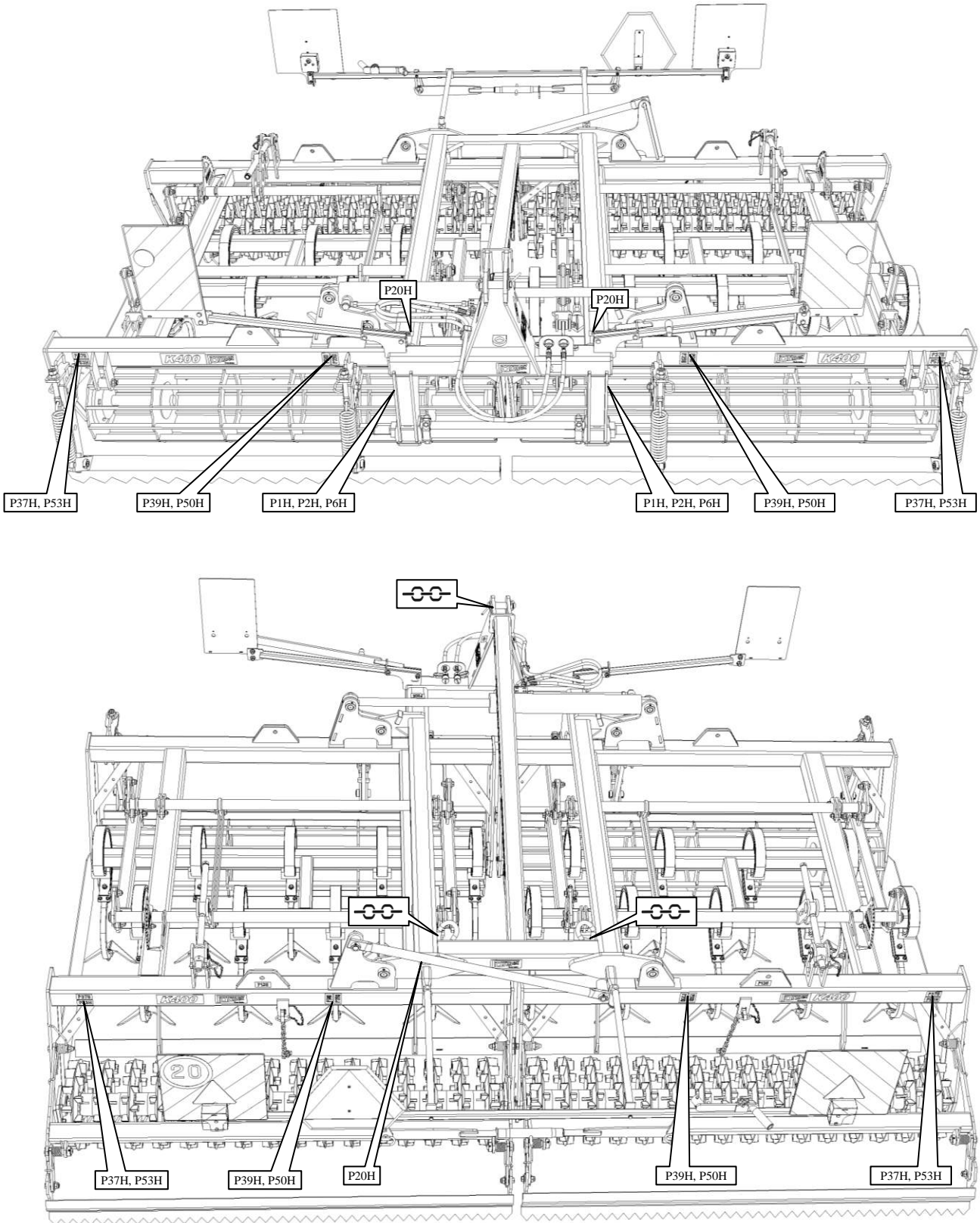

1. DESCRIPTION:

The machine is structurally solved as mounted unfolding. The machine consists of a supporting frame with three-point mounting for aggregation with a tractor. Side folding frames with the working parts of the machine are attached to the supporting frame. As for the construction, the control of the folding side frames is managed by hydraulic elements controlled by the driver from the tractor.

1.1 WORKING PARTS OF THE MACHINE

- 1.1.1 Spring-mounted front leveller
- 1.1.2 Front slatted roller \varnothing 400
- 1.1.3 Share section
 - 1.1.3.1 Arrow shares in 2 rows with a levelling slat
 - 1.1.3.2 Chisel shares in 4 rows
- 1.1.4 Rear roller
 - 1.1.4.1 Slatted roller \varnothing 400
 - 1.1.4.2 Cross-kill roller \varnothing 400 with a cleaner
- 1.1.5 Rear leveller

Picture 2 – Description of K400NS

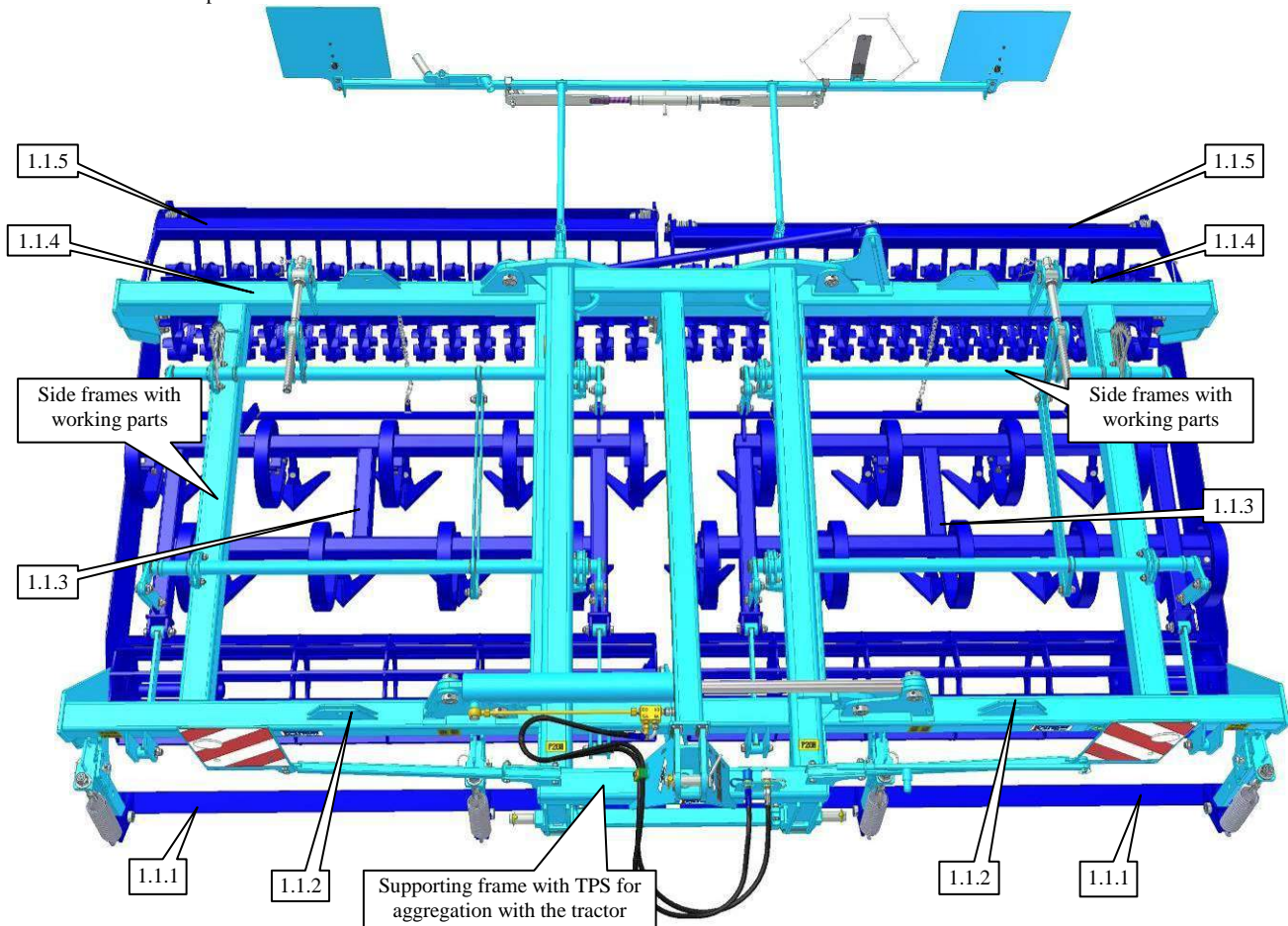

OPTIONAL ABOVE-STANDARD MACHINE EQUIPMENT

- Mechanism for hydraulic adjustment of the height of front levellers; this mechanism only requires one independent hydraulic circuit.
- Mechanism for hydraulic adjustment of the depth of ploughshares; this mechanism only requires one independent hydraulic circuit.
- Mechanism for cultivating the compacted tracks behind the tractor.

1.2 HYDRAULICS OF THE MACHINE



It is forbidden to disassemble the parts of the hydraulic system that are under pressure.

Hydraulic oil that penetrates skin under high pressure causes serious injuries. In case of an injury immediately seek medical help.

Hydraulic scheme K400NS

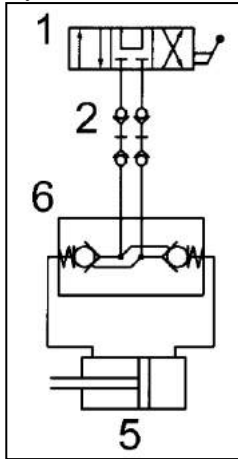

- | |
|---|
| <p>1- Controlling distributor in the tractor
 2- Hydraulic snap couplings
 5- Hydraulic cylinder of side frame unfolding
 6- Hydraulic closing valve of the cylinder for side frame</p> |
|---|

2. ASSEMBLY OF THE MACHINE AT THE CUSTOMER'S SITE



- The operator must execute the assembly according to the producer's instructions, if possible in cooperation with a professional service technician determined by the producer.
- The operator must execute a functional test of all assembled parts after the completion of the assembly of the machine.
- The operator must ensure that the manipulation with the machine by lifting equipment corresponds with Chapter "C".

3. PUTTING INTO OPERATION



- Before you take over the machine, test and check it for any damages incurred during transportation and check that all parts included in the delivery note have been delivered.
- Before you put the machine into operation, read the operating manual carefully, particularly chapters A-D p.4-8. Learn about the control elements of the machine and its overall function before the first use.
- When working with the machine, observe the instructions in the manual as well as generally valid rules for the safety at work, protection of health, fire and traffic safety and protection of environment.
- The operator must check the machine before every use (putting into operation) for aspects in the field of completeness, safety at work, work hygiene, fire safety, traffic safety and protection of environment.
- **IF THE MACHINE SHOWS SIGNS OF DAMAGE, IT MUST NOT BE PUT INTO OPERATION!!**
- Execute aggregation of the machine with the tractor on an even and compact surface.
- When working on slopes, observe the lowest slope accessibility of the whole set **TRACTOR – MACHINE**.
- Before turning on the engine of the tractor, check that there are no people or animals in the working area of the set and press the warning sound signal.
- The operator is responsible for safety and for all damages caused by the operation of the tractor and the attached machine.
- The operator must observe technical and safety regulations of the machine determined by the producer when working with the machine.
- The operator must raise the machine when turning at the plough turning end, i.e. the working parts must not be in the ground.
- The operator must observe the prescribed working depths and speeds set in the operating manual in Chart 2/p.4 when working with the machine.
- The operator must lower the machine to the ground and secure the set against movement before leaving the cabin of the tractor.

3.1 AGGREGATION TO THE TRACTOR

- The machine may only be connected to a tractor whose standby weight equals or is higher than the total weight of the attached machine.
- The operator must observe all generally valid regulations for the safety at work, protection of health, fire safety and protection of environment.
- The operator may only attach the machine to a tractor which is equipped with a rear three-point mounting and a functional undamaged hydraulic system.

Chart 4 - Requirements for the tractive equipment for work with the machine

(5) Requirement for the engine power of the tractor for K400NS		80-120 kW*
(6) Requirement for the tractor TPS	(7) distance of the bottom suspension hinges (at the axes of the hinges)	1010+/- 1,5 mm
	(8) Ø holes of the bottom suspension joints for the suspension hinge pins of the machine	Ø37,5 mm
	(18) Ø holes of the upper suspension joint for the suspension hinge pin of the machine	Ø32,5 mm
(9) Requirement for the hydraulic system of the tractor	(10) circuit of side frame unfolding	(14) Pressure in the circuit 200bar, 2 sockets for snap coupling ISO 12.5

* These values are only as recommended tractive equipment. The actual tractive force may substantially differ according to the processing depth, soil conditions, slope of the land, wear and tear of working parts and their adjustment.

- Connect the machine with the suspension TPS pole to the lower arm of the tractor TPS and secure the TPS arms with pegs against disconnection.



When connecting the machine, there must not be any people in the area between the machine and the tractor.

3.2 CONNECTING THE HYDRAULICS

- Connect the hydraulics only when the hydraulic circuits of the machine and the tractor (aggregate) are without any pressure.
- The hydraulic system is under great pressure. Check regularly for leakages and immediately eliminate any visible damage to all distribution, tubes and screw joints.
- When checking for and eliminating leakages, use appropriate equipment.
- Use the plug (on the machine) and the socket (on the tractor) of the same type of snap coupling when connecting the hydraulic system of the machine to the tractor.
- For easier specification, the individual circuit is coloured (see Picture3).

Picture 3 – Coloured marking of the hydraulic circuits on the machine

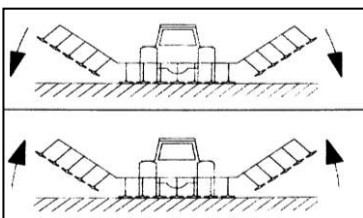

WHITE DUSTER – side frames into working position

BLUE DUSTER – side frames into transport position

- The hydraulic scheme for mounted combinator is shown in Chapter 1.2 (p.10).



In order to rule out unintentional movement of the hydraulics or movement caused by third persons (children, passengers), the controlling distributors in the tractor must be secured or blocked and the controlling unit switched off if the machine is not used or if it is in the transport position.

3.3 **FOLDING AND UNFOLDING THE MACHINE**



When executing any of the hydraulic movements, slow down the moving parts of the machine before position stop by choking a relevant valve on the tractor control!



- The hydraulics of the machine must be connected to a push-pull hydraulic circuit.
- The operator must ensure that there are no people or animals within the reach of the side frames during their unfolding or folding (i.e. in the place of their position stop) and that no one puts their fingers or other body parts into the area of the joints.
- Execute unfolding or folding on flat and solid surfaces or crosswise to a slope.
- Only fold and unfold the machine when it is lifted in the shoulders, i.e. it does not lie on the surface (ground).
- Remove any soil stuck on the folding places as it may disturb the function and cause damage to the mechanics.
- Monitor the side frames during unfolding or folding and fold them smoothly until the end position.

3.3.1 **FOLDING THE MACHINE INTO THE TRANSPORT POSITION**

- Clean the machine from impurities.
- Lift the machine from the surface by controlling the shoulders of the three-point mounting of the tractor.

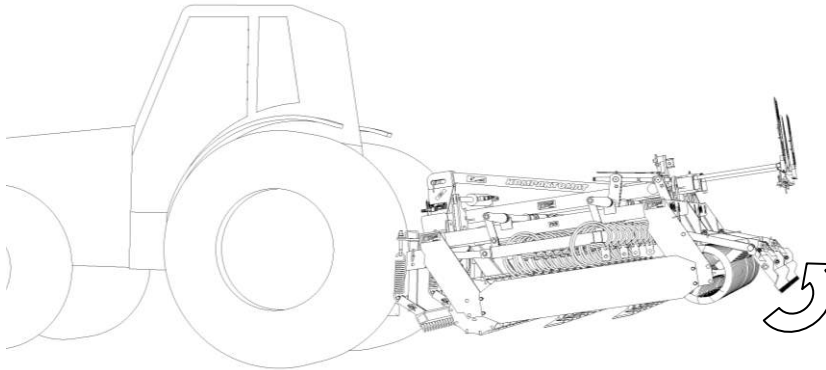

- Smoothly unfold the side frames using the tractor circuit for “UNFOLDING” until the final position of the piston-rod.

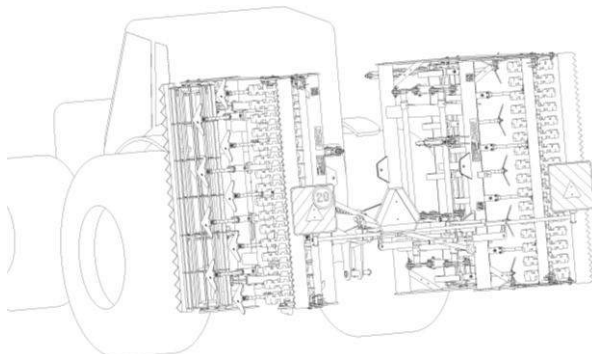
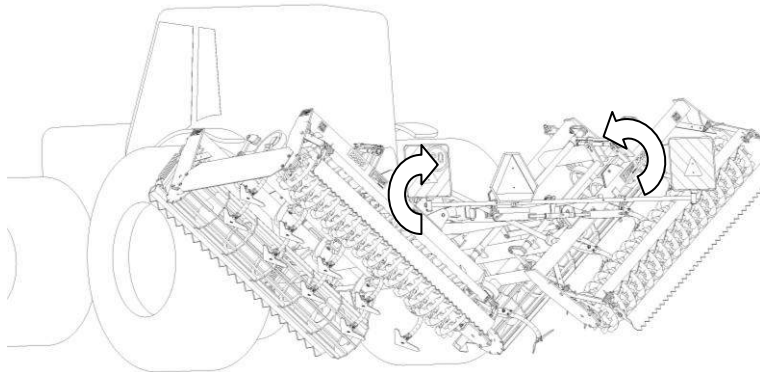

- Block or close the circuit.
- Secure side frames by the mechanical rod.

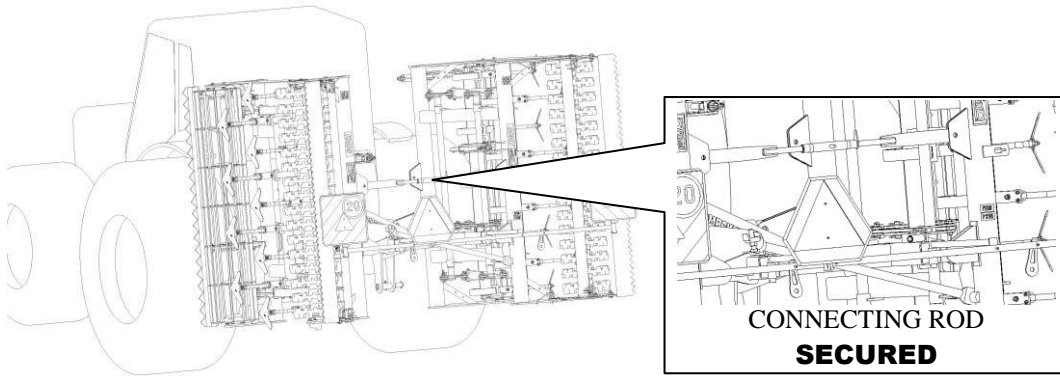

3.3.2 UNFOLDING THE MACHINE INTO THE WORKING POSITION

- Release the side frames by the mechanical rod.

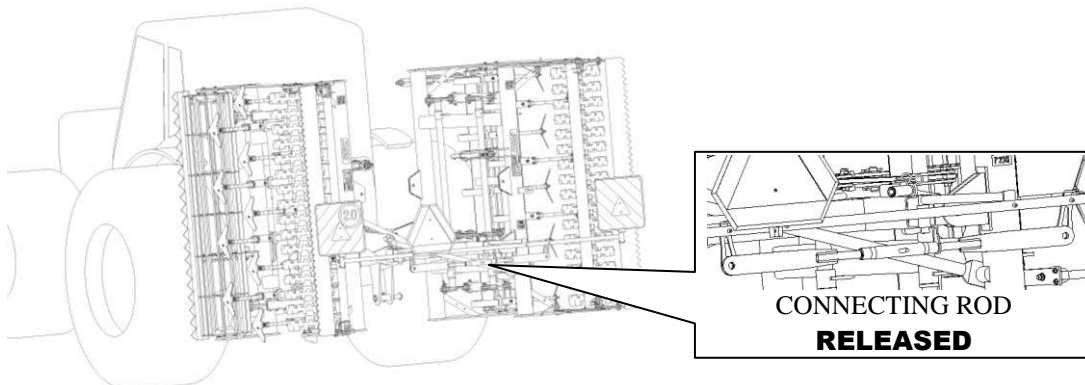

- Smoothly unfold the side frames with the use of the tractor circuit for "UNFOLDING" until fully unfolded.

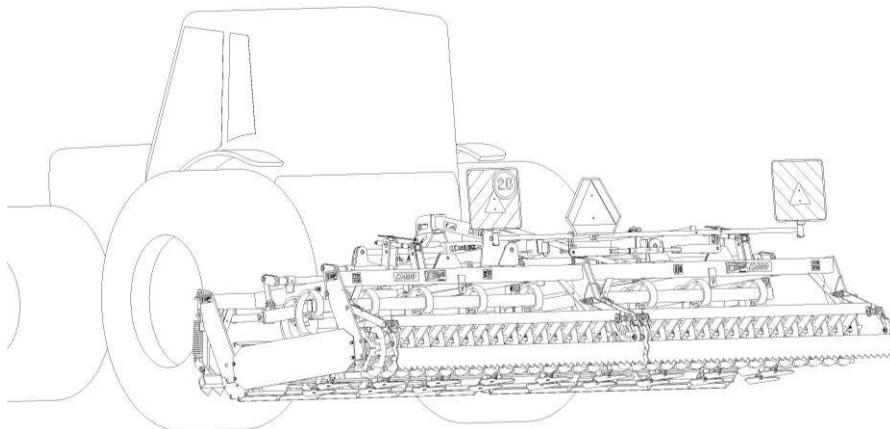
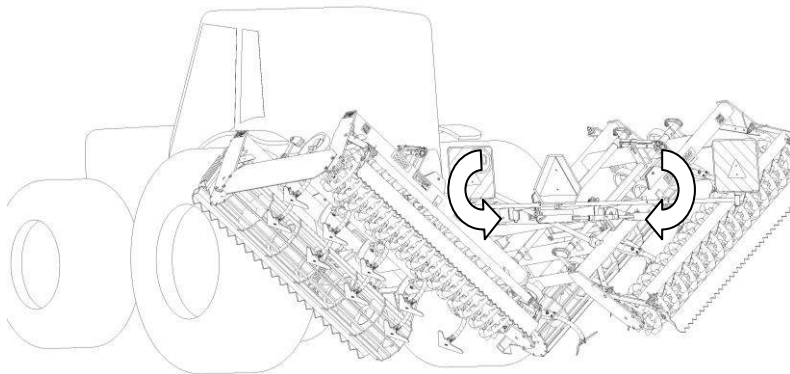

- Block or close the circuit.
- Lower the machine onto the surface by controlling the shoulders of the three-point mounting of the tractor.

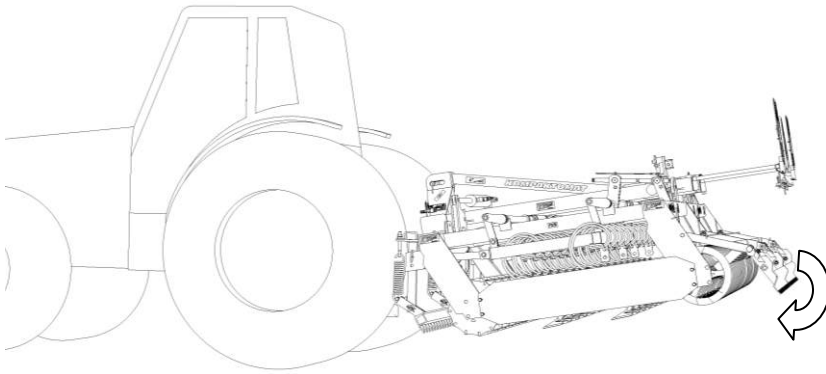

4. TRANSPORTING THE MACHINE ON GROUND COMMUNICATIONS

4.1 Put the machine into the transport position.
Transport position for the machine (Chapter 3.3.1)

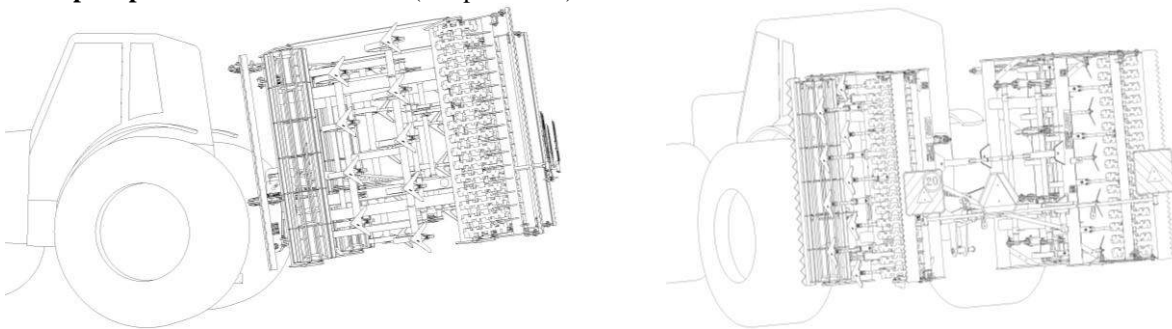

- Attach the unfolded machine to the rear three-point mounting of the tractor using TSP 3 pins.
 - According to Chapter 3.3.1, fold the machine into the transport position and secure the side frames by the connecting rod.
 - The machine must be equipped with removable shields displaying the boundaries, functional lighting and a board of rear label for slow vehicles (pursuant to EEC No.69).
 - The lighting must be turned on when in operation on ground communications.
 - The tractor must be equipped with a special light appliance with orange colour that must be turned on when in operation on ground communications.
 - The maximum permissible transport speed for the operation of the machine on ground communications is **20km/hour**.
- 4.2** The operator must drive with increased caution when transporting the machine on ground communications due to the transport dimensions of the machine.
- 4.3** The operator must observe valid regulations for the operation on ground communications (acts, decrees) after connecting the machine to the tractor due to the changes in the load of axles. The driving properties of the set also change in relation to the character of the terrain; therefore adapt the method of driving to these conditions.
- 4.4** If requested, the operator shall submit the technical certificate of the machine according to the valid regulations for the operation on ground communications (only in the Czech Republic).
- 4.5** When reversing with the attached machine, the operator shall ensure a sufficient view from his or her position as the driver of the tractor. If the view is not sufficient, the operator shall call a qualified and instructed person.
- 4.6** The operator must secure the shoulders of the rear tractor TPS in the transport position when transporting the machine on ground communications, i.e. by the handle of the hydraulic control of the shoulders, in order to prevent a sudden drop of the shoulders. At the same time, the shoulders of the rear tractor TPS must be secured against side swing.
- 4.7** When transporting the machine on ground communications, the operator must observe the related valid acts and decrees that specify the relations of the load on the axles of the tractor in relation to the transport speed.
- 4.8** **It is forbidden to transport the machine on ground communications when visibility distance is reduced!!**



5. ADJUSTING THE WORKING PARTS OF THE MACHINE

Picture 4 – Adjusting the working parts of the machine

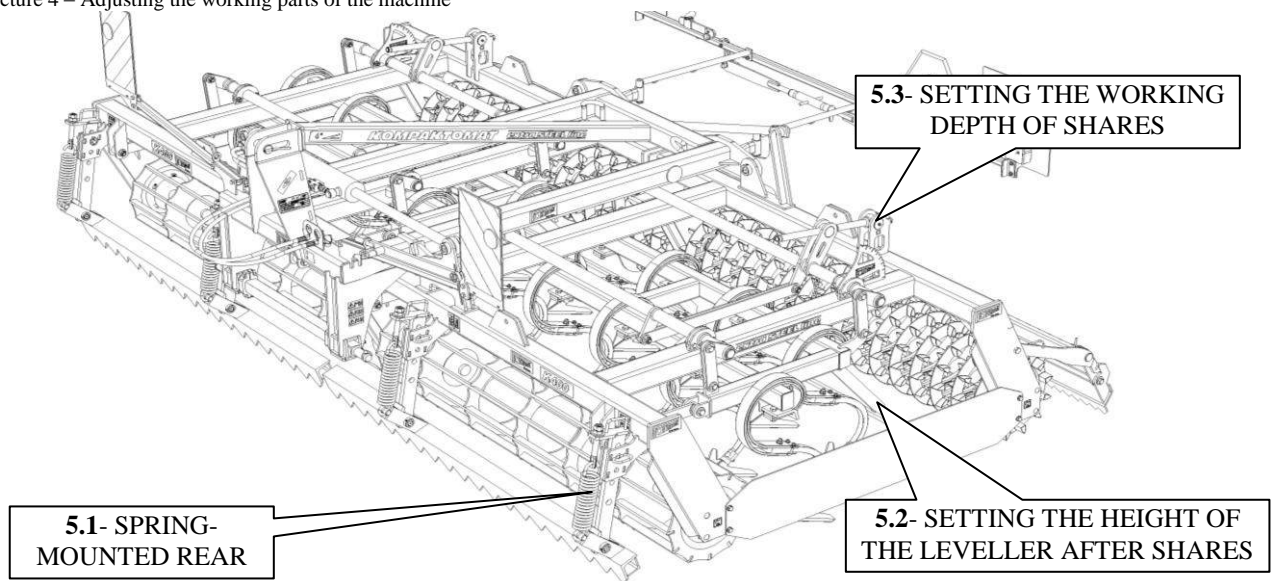

5.1 ADJUSTING THE SPRING-MOUNTED FRONT LEVELLER

- The height of the front leveller may be adjusted as well as the spring force of the leveller.
 - Perform the adjustment of front levellers when the machine is unfolded in the working position and standing on the working sections at the same time.
- 5.1.1** Adjust the height of the front leveller by moving the lever in the holder and securing the position by a peg. The height of the front leveller is adjusted in relation to the size of clods and curvature of the field so that the leveller is about 3 to 5 cm above the level of the working rollers when the machine is lowered to the working rollers. When needed, the leveller may be set higher or lower.
- 5.1.2** The spring-mounting of the front leveller is secured by a tractive spring. Its strain capacity may be changed by a tension screw. The spring is preset to $L=340-345\text{mm}$, the maximum prestressing in rest mode of the leveller is $L_{\text{max}}=370\text{mm}$. The prestress of the spring is selected on the basis of the field type (according to the size of clods). The larger the clods are, the larger the prestress is necessary.

Picture 5 – Adjusting the front leveller

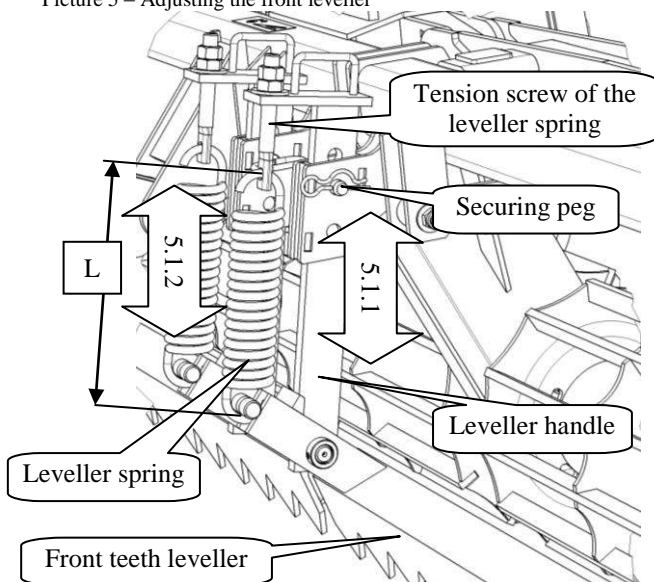

Picture 6 – Front leveller work



5.2 ADJUSTING THE DEPTH OF THE SHARE SECTION



Apply heightened caution when adjusting the depth of the shares due to the potential rolling of the working roller. Adjust the depth of the shares when the machine is unfolded into the working position and standing still. The machine must be raised in the shoulders of the tractor so that there is a gap of up to 50 mm between the solid ground and working sections.

The working depth of the shares is adjusted by turning the handle with the trapezoid thread. The handle is located on each frame of the machine. The depth is set by turning the mounting handle. For transparent setting of the depth, there are pointers with depth gauges near the handles. The soil processing depth is selected according to the type of crop you want to grow. Approximate values of processing depth are provided in Chart 5.

Picture 7 – Setting the processing depth

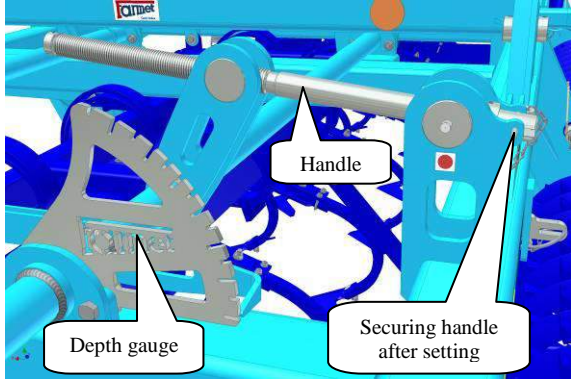

Picture 8 – Setting the processing depth

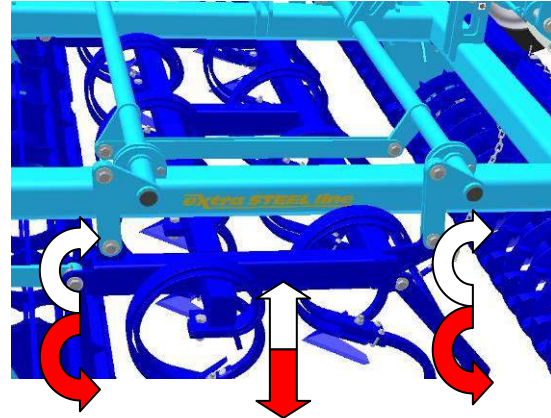

Picture 9 – Setting the processing depth

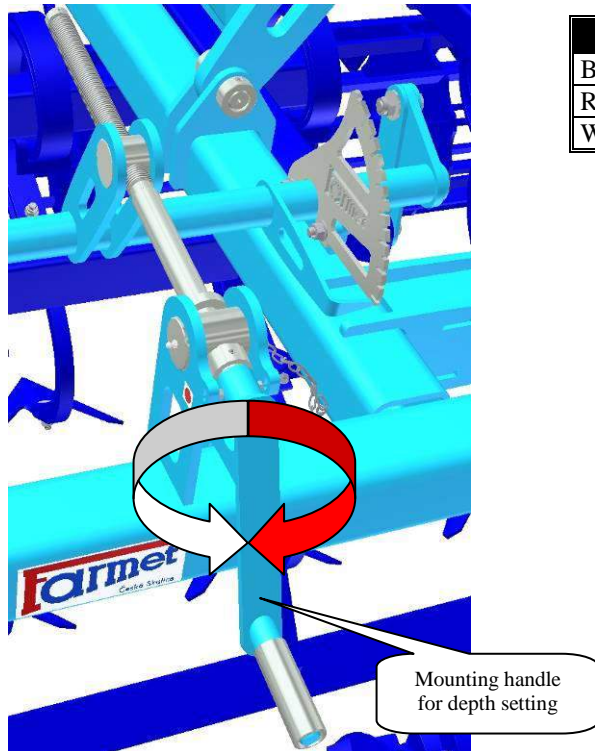

Chart 5 – Approximate processing depth acc. to crops

CROP	DEPTH
Beet	2-3 cm
Rape	3-5 cm
Wheat, barley, oats	5-8 cm

5.3 ADJUSTING THE LEVELLER HEIGHT BEHIND SHARES

Perform the adjustment of the height of the levellers when the machine is unfolded in the working position and standing still. The machine must rest on the working sections.

The leveller behind shares is used for levelling the cultivated soil after the rear row of arrow shares before the rear roller. The height of the leveller behind shares is adjusted by the chain between the leveller and the bearing frame. The chain is screwed to the leveller and it is passed through and eye in the bearing frame and secured. The height of the leveller is set in relation to the working depth of the shares. The deeper the processing is, the higher the leveller needs to go. Set the leveller height “V” above solid ground between 60 – 100 mm.

Picture 10 – Adjusting the leveller behind shares

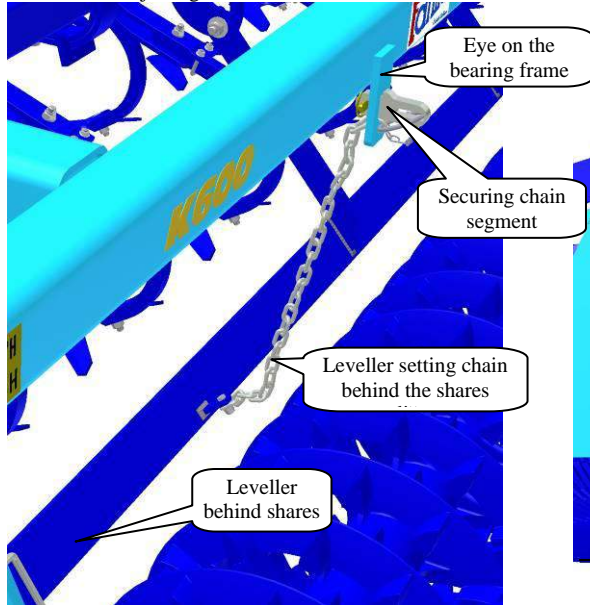

Picture 11 – Height of the leveller behind shares

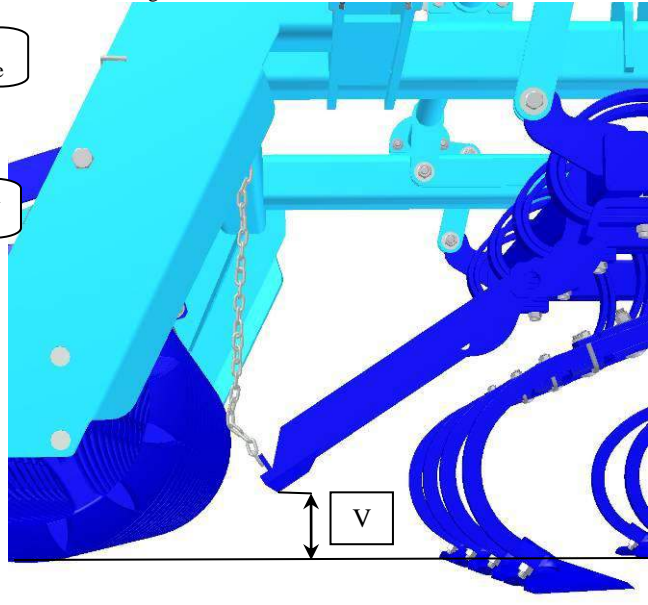

6. MAINTENANCE AND REPAIRS OF THE MACHINE

Observe the safety instructions and regulations for maintenance and treatment.

- Check that all screws and other assembly points are tight **before each use of the machine** and whenever needed.
- Regularly check the wear and tear of the working parts of the machine. The quality of work decreases with the worn working parts.
- Lubricate all indicated lubrication places according to Chapter 6.1.
- Replace shares according to Chapter 6.2.
- Adjusting, cleaning and lubricating the machine may only be performed when the machine is standing still, i.e. the machine is stopped and is not working.
- When adjusting, cleaning, maintaining and repairing the machine, secure the folding and rotary parts of the machine that could put the operator in danger by fall or other movement.
- When repairing the unfolded machine parts, use a suitable support device leaning against labelled places or appropriate places.
- For attaching the machine when manipulating it with the use of lifting equipment, use only places marked by stick-on labels with the symbol of a chain “”.
- If there is a defect or damage on the machine, immediately turn off the tractor engine and secure the engine from turning on, secure the set and the machine against movement ⇒ then you can remove the defect.
- When repairing the machine, use only original spare parts, suitable tools and protective equipment.
- Order original spare parts according to the Spare Parts Catalogue.
- If you have to weld during the repair and have the machine attached to the tractor at the same time, the supply cables have to be disconnected from the alternator and accumulator.
- Keep the machine clean.



Do not use a high-pressure cleaner or direct water jet for cleaning hydraulic rollers (piston-rods) and bearings. The bearings and seals are not waterproof under high pressure.

6.1 LUBRICATION PLAN FOR THE MACHINE

Regular lubrication of lubricating places increases the usable life of the nodes and the machine. Perform lubrication according to the “Lubrication Plan”.

When lubricating the bearings of the rollers, observe caution so that you do not damage the bearings. When lubricating the bearings of the rollers, turn the roller around so that the lubricant spreads evenly.

Lubricate the nodes until clean lubricant is coming out of them. Then wipe the lubricant off.

Chart 6 – Places and intervals of lubrication

PLACE FOR LUBRICATION		INTERVAL	LUBRICANT
Controlling handle	Picture 12	-Daily, when working on the field.	-Plastic lubricant -*Plastic lubricant based on lithium
*Rear roller bearings	Picture 13	-Always before work with the machine.	
*Front roller bearings	Picture 14	-Always after the work and before putting the machine out of operation.	

Picture 12 – Lubricating the controlling handle

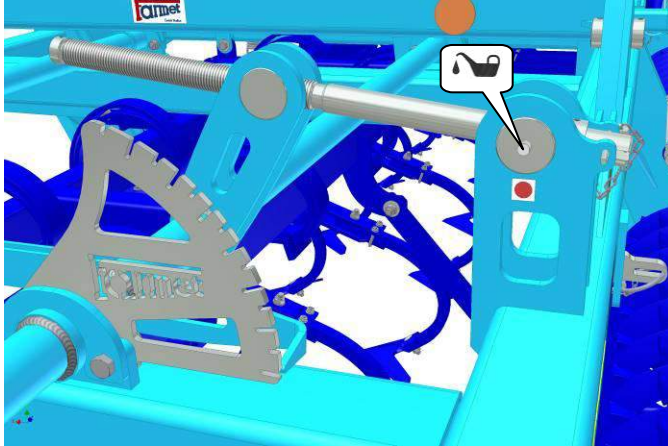

Picture 13 – Lubricating the rear roller bearings

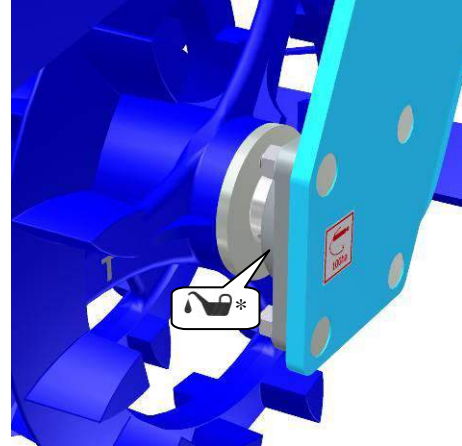

Picture 14 – Lubricating the front roller bearings

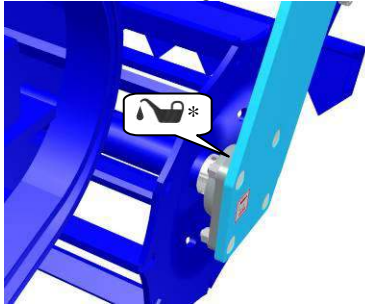

MANIPULATION WITH LUBRICANTS:

- Treat oils and lubricants as hazardous waste according to valid regulations and acts.
- Protect yourself from direct contact with oils by using gloves or protective lotion.
- Wash oil stains on skin thoroughly with warm water and soap. Do not clean the skin with petrol, diesel oil or other dissolving agents.
- Oil or lubricant is poisonous. If you swallow any, immediately seek a doctor.
 - Keep oil and lubricants out of reach of children.



6.2 REPLACEMENT OF WORN SHARES

- Always observe the safety regulations and instructions when replacing shares.
- The machine must be aggregated with the tractor according to chapter 3.1/p.11 when shares are replaced. The tractor must be turned off and the operator or repairer must prevent free access of unauthorized persons to the tractor.
- Replace the shares on solid and even surface and when the machine is standing still.
- If the hydraulic system of the tractor is not tight, you have to provide mechanical supports for the machine pole.

6.2.1 REPLACEMENT OF WORN SHARES ON THE SIDE FRAMES

- Put the machine into the transport position according to Item 3.3.1/p.12, including the protection of the side frames.
- Replace the shares you can reach.

- To replace shares that you cannot reach, lower the folded machine into the transport position on the shoulders of the rear TPS of the tractor. In this position, secure the machine by a mechanical rest against unexpected fall.

Picture 15 – Replacement of shares on the side frames

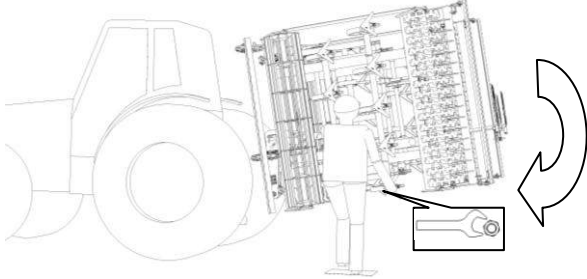

RECOMMENDED TIGHTENING MOMENTS OF SCREW CONNECTIONS

SCREW CONNECTION	TIGHTENING MOMENT	NOTE
M8x1	8Nm	Fastening set screws of bearings
M8 (8.8)	25Nm	Hook straps of arrow shares
M10 (8.8)	50Nm	Screws for chisel shares
M12 (5.6)	38Nm	Hook screws of arrow shares
M12 (8.8)	87Nm	House bearings
M12 (12.9)	147Nm	Screws of arrow shares
M16 (8.8)	210Nm	Suspension of share frames, folding levellers to the frames
M20 (8.8)	410Nm	Prestress of tractive springs of front levellers
HYDRAULIC + AIR JOINTS		
M16x1,5	60Nm	Hydraulic screwing
M22x1,5	140Nm	Hydraulic screwing

7. STORING THE MACHINE

When you put the machine out of operation for a longer-period of time:

- Store the machine under a roof, if possible.
- Store the machine on an even and solid ground with sufficient bearing capacity.
- Clean the machine before storing and make sure that the machine is not damaged during the storage. Pay special attention to all labelled lubricating places and lubricate the machine according to the lubrication plan.
- Store the machine with folded frames in the working position.
- Before storing the machine, set the depth of the shares to about 1cm so that the working rollers are in contact with the surface and the shares only secure the machine from a potential movement during the storage of the machine.
- Prevent access by unauthorized persons to the machine.

Picture 16 - position of the machine during storage

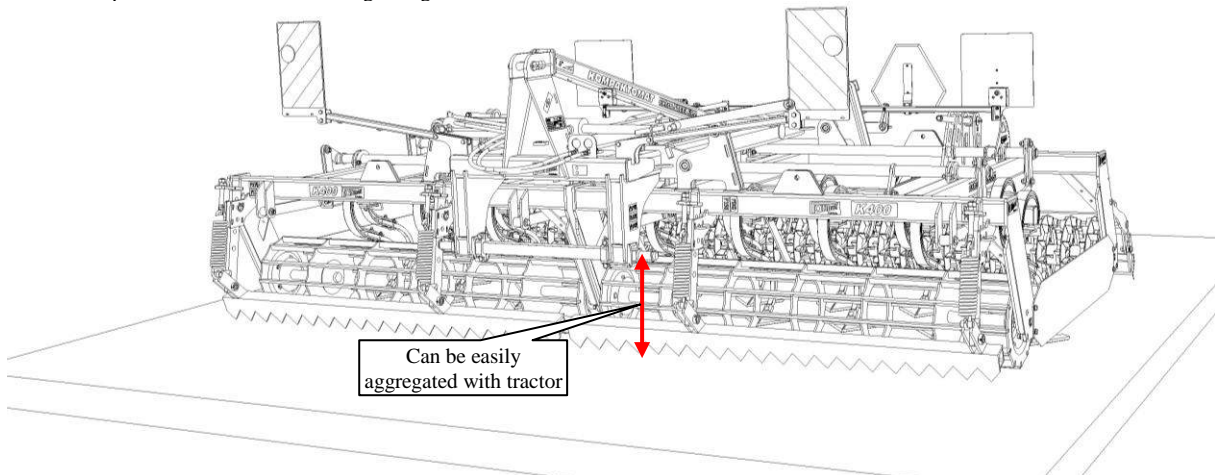

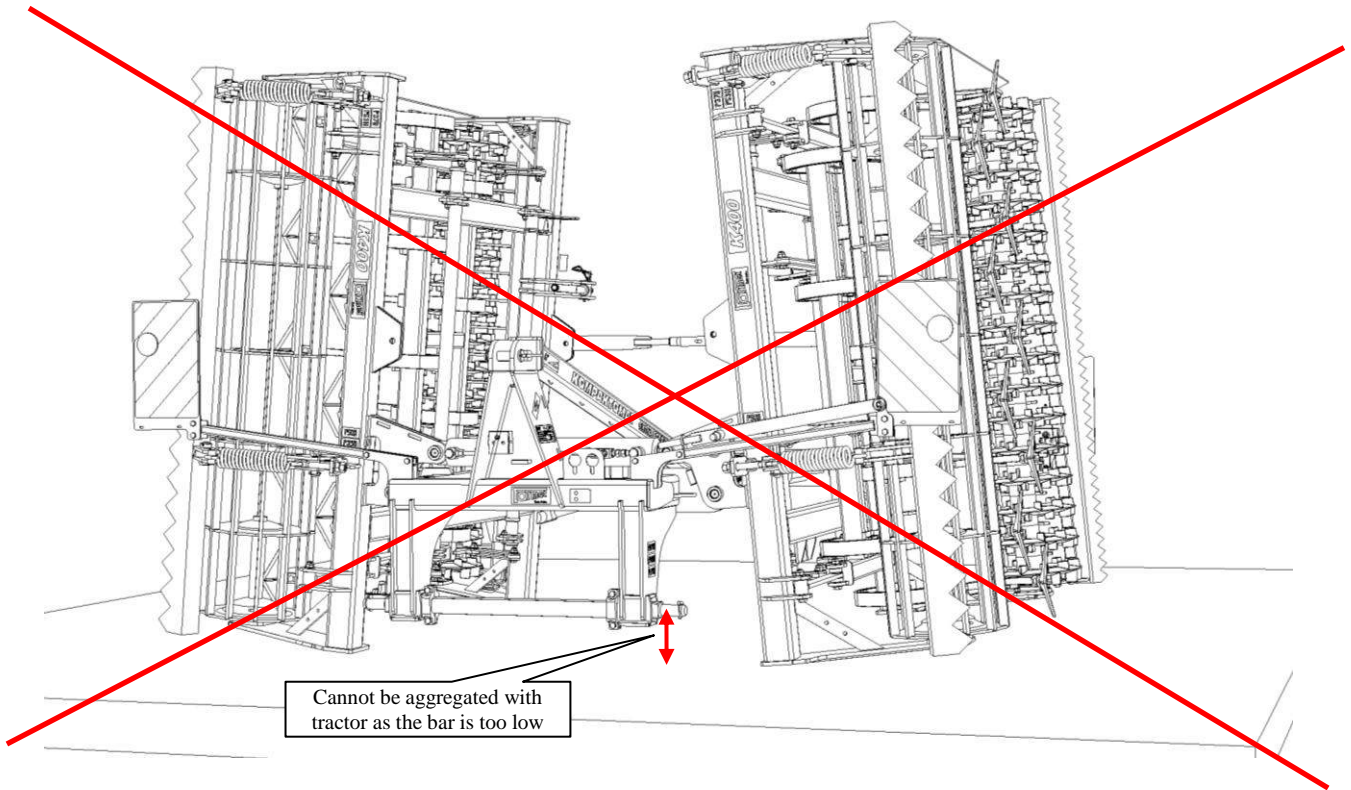

8. PROTECTION OF ENVIRONMENT

- Check the tightness of the hydraulic system regularly.
- Replace or repair hydraulic tubes or other parts of the hydraulic system showing signs of damage, before oil starts to leak.
- Check the condition of hydraulic tubes and execute their timely replacement. The usable life of hydraulic tubes also includes the storage time.
- Treat oils and lubricants according to valid acts and regulations on wastes.

9. DISPOSAL OF THE MACHINE AFTER THE END OF ITS USABLE LIFE

- The operator must make sure that the steel parts and parts in which the hydraulic oil or lubricant is used are separated for disposal.
- The operator will cut the steel parts according to safety regulations and hand them over to the scrap yard for secondary raw materials. For other parts follow the valid acts on wastes.

10. SERVICES AND WARRANTY CONDITIONS

10.1 SERVICES

After-sale service is ensured by the sales representative after consultation with the manufacturer or directly by the manufacturer. Spare parts are supplied by individual sellers via the nationwide sales network. Spare parts should be ordered according to the official spare-part catalogue issued by the manufacturer.

10.2 WARRANTY

- 10.2.1** The manufacturer gives a 24-month warranty for the following machine parts: The main frame, the axle and the shaft (tow bar). The warranty period for the other parts of the machine is 12 months. The warranty period starts on the date of sale of a new machine to the end user.
- 10.2.2** The warranty applies to hidden defects that become evident within the warranty period provided that the machine has been properly used and maintained according to the Operating manual.
- 10.2.3** The warranty does not apply to common mechanical wear and tear of the exchangeable parts (e.g. shares, blades etc.)
- 10.2.4** The warranty does not apply to indirect consequences (such as a lower service life, etc.) resulting from a possible damage.
- 10.2.5** The warranty is engaged on the particular machine and does not become extinct with changing the owner.
- 10.2.6** The warranty is limited to dismantling and assembling or possibly to replacement or repair to the given defective part. The decision on replacing or repairing the defective part is the sole responsibility of the workshop authorized by Farmet.
- 10.2.7** For the time of the warranty period, only an authorised servicing technician of the producer may perform repairs or other interventions into the machine. Otherwise the warranty will not be acknowledged. This provision does not apply to the replacement of wearable spare parts (see point 10.2.3).
- 10.2.8** The warranty is conditioned by using original spare parts of the manufacturer.

Farmet a. s.
Jiřinková 276
ČESKÁ SKALICE 552 03



Tel.: 00420 491 45 01 40
491 45 01 22
Fax.: 00420 491 45 01 36

LETTER OF GUARANTEE

TYPE OF MACHINE:

YEAR OF PRODUCTION/SERIAL NUMBER: _____

CONFIRMATION OF INSPECTION: _____

ADDRESS (BUYER): _____

ADDRESS (SELLER): _____

WARRANTY:

- I. The manufacturer gives a 24-month warranty for the following machine parts: The main frame, the axle and the shaft (tow bar). The warranty period for the other parts of the machine is 12 months. The warranty period starts on the date of sale of a new machine to the end user.
- II. The warranty applies to hidden defects that become evident within the warranty period provided that the machine has been properly used and maintained according to the Operating manual.
- III. The warranty does not apply to common mechanical wear and tear of the exchangeable parts (shares, blades, etc.).
- IV. The warranty does not apply to indirect consequences (such as a lower service life, etc.) resulting from a possible damage.
- V. The warranty is engaged on the particular machine and does not become extinct with changing the owner.
- VI. The warranty is limited to dismantling and assembling or possibly to replacement or repair to the given defective part. The decision on replacing or repairing the defective part is the sole responsibility of the workshop authorized by Farmet.
- VII. For the time of the warranty period, only an authorised servicing technician of the producer may perform repairs or other interventions into the machine. Otherwise the warranty will not be acknowledged. This provision does not apply to the replacement of wearable spare parts (see point III).
- VIII. The warranty is conditioned by using original spare parts of the manufacturer.

CONFIRMATION OF THE PRODUCTION
COMPANY

CONFIRMATION OF THE BUYER

DATE

DATE OF FIRST SALE

ⒸZ ES PROHLÁŠENÍ O SHODĚ
ⒸGB CE CERTIFICATE OF CONFORMITY
ⒸD EG-KONFORMITÄT SERKLÄRUNG
ⒸF DÉCLARATION CE DE CONFORMITÉ
ⒸRU СЕРТИФИКАТ СООТВЕТСТВИЯ ЕС
ⒸPL DEKLARACJA ZGODNOŚCI WE

1. ⒸZ My ⒸGB We ⒸD Wir ⒸF Nous ⒸRU Мы ⒸPL My: **Farmet a.s.**
Jiřinková 276
552 03 Česká Skalice
Czech Republic
DIČ: CZ46504931
Tel/Fax: 00420 491 450136

ⒸZ Vydáváme na vlastní zodpovědnost toto prohlášení. ⒸGB Hereby issue, on our responsibility, this Certificate. ⒸD Geben in alleiniger Verantwortung folgende Erklärung ab. ⒸF Publiions sous notre propre responsabilité la déclaration suivante. ⒸRU Под свою ответственность выдаем настоящий сертификат. ⒸPL Wydajemy na własną odpowiedzialność niniejszą Deklarację Zgodności.

2. ⒸZ Strojní zařízení: - název : **Nesený sklápěný kompaktomat**
ⒸGB Machine: - name : **Mounted unfolding Kompaktomat**
ⒸD Fabrikat: - Bezeichnung : **Klappbare Anbaugeräte Kompaktomat**
ⒸF Machinerie: - dénomination : **Compactomats de portage basculants**
ⒸRU Сельскохозяйственная машина: - наименование : **Навесной складной компактомат**
ⒸPL Urządzenie maszynowe: - nazwa : **Zawieszony opuszczany Kompaktomat**

- typ, type : **K 400 NS**
- model, modèle : **K 400 NS I., K 400 NS II.**
- ⒸZ výrobní číslo :
- ⒸGB serial number
- ⒸD Fabriknummer
- ⒸF n° de production
- ⒸRU заводской номер
- ⒸPL numer produkcyjny:

3. ⒸZ Příslušná nařízení vlády: č.176/2008 Sb. (směrnice 2006/42/ES). ⒸGB Applicable Governmental Decrees and Orders: No.176/2008 Sb. (Directive 2006/42/ES). ⒸD Einschlägige Regierungsverordnungen (NV): Nr.176/2008 Slg. (Richtlinie 2006/42/ES). ⒸF Décrets respectifs du gouvernement: n°.176/2008 du Code (directive 2006/42/CE). ⒸRU Соответствующие постановления правительства: № 176/2008 Сб. (инструкция 2006/42/ES). ⒸPL Odpowiednie rozporządzenia rządu: nr 176/2008 Dz.U. (Dyrektywa 2006/42/WE).

4. ⒸZ Normy s nimiž byla posouzena shoda: ⒸGB Standards used for consideration of conformity: ⒸD Das Produkt wurde gefertigt in Übereinstimmung mit folgenden Normen: ⒸF Normes avec lesquelles la conformité a été évaluée: ⒸRU Нормы, на основании которых производилась сертификация: ⒸPL Normy, według których została przeprowadzona ocena: ČSN EN ISO 12100, ČSN EN ISO 4254-1.

ⒸZ Schválil ⒸGB Approve by dne: 01.06.2012
ⒸD Bewilligen ⒸF Approuvé
ⒸRU Утвердил ⒸPL Uchwalił

p. Gavlas Dušan
technický ředitel
Technical director

Farmet a.s.
Jiřinková 276
552 03 Česká Skalice
DIČ CZ46504931
38

V České Skalici dne: 01.06.2012

Ing. Karel Žďárský
generální ředitel společnosti
General Manager

