

 **RIPUNTATORE PIEGHEVOLE**

 **FOLDABLE SUBSOILER**

 **KLAPPBARER TIEFENLOCKERER**



Mega craKer KX 320
410
500

Mega craKer KX

RIPUNTATORE PIEGHEVOLE
FOLDABLE SUBSOILER
KLAPPBARER TIEFENLOCKERER

Mod. KX 320 - 410 - 500

Per trattori fino a 500HP / For tractors up to 500HP / Für Schlepper bis 500 PS



Frantumazione e livellamento garantito grazie ai rulli Franter di ultima generazione, ancora più performanti e con manutenzione ridotta.



Crumbing and levelling are guaranteed by the state-of-the-art rollers, offering an even higher performance and requiring less maintenance



Zerkleinerung und Nivellierung gewährleistet Dank der neuesten, noch leistungsfähigeren und wartungsarmen Entwicklung

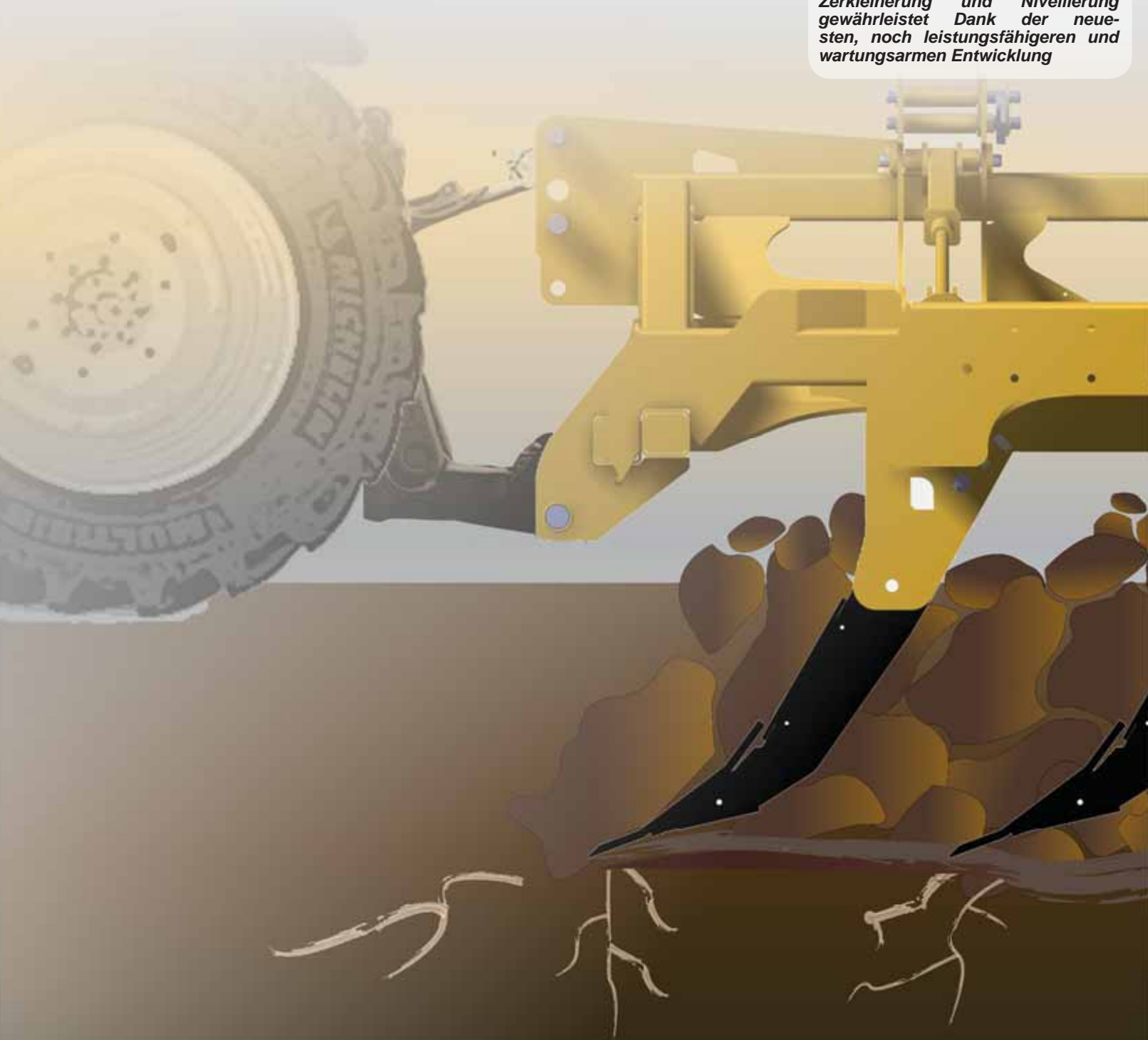



FRANTER **S**YSTEM



8 winning points



2,50 m

Ingombro per il trasporto contenuto a 2,50 m.

Reduced transport width (2,5 m.)

Transportbreite 2,5 m.



Aratura / Plowing / Pflügen

Sistema di attacco unificato per trattori di grande potenza (3° cat., 4° cat., USA)

Unified hitching device for high-power tractors (Cat. 3, cat. 4 USA)

Standardisiertes Kuppelungs-Aggregat für Schlepper mit höher Kraft (Kat. 3, 4 u. USA)



Controllo della profondità di lavoro con circuito idraulico incrociato. Ampia regolazione grazie al nuovo parallelogramma.

Working depth control with a cross hydraulic circuit. Broad adjustment possibility thanks to the new parallelogram.

Kontrolle der Arbeitstiefe mit gekreuztem hydraulischen Kreislauf. Umfangreiche Einstell-Möglichkeit Dank dem neuen Parallelogramm

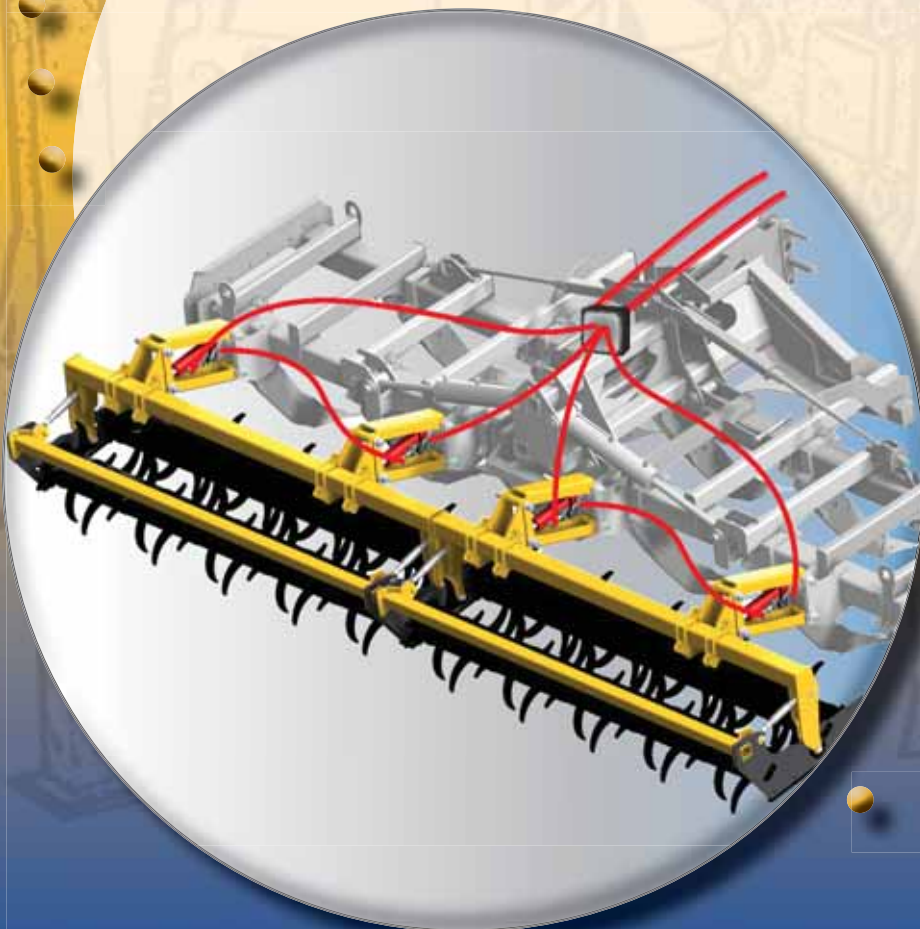

Bridge solution, studiato per garantire il flusso e la profondità di lavoro (fino a 65 cm)

Bridge solution, designed to guarantee a flow and the max. working depth (up to 65 cm)

Bridge solution, die deswege wurde, um den Durchgang der E max. Arbeitstiefe (bis 65 cm) gewährleisten.



Riduzione dei tempi di lavoro;
Riduzione dei consumi

Decrease of the working time;
Decrease of fuel consumption

Kürzere Arbeitszeit;
Weniger Kraftstoffverbrauch.

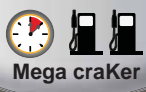

Smontaggio rapido del vomere

Quick-release plowing tip

Schnellwechsel-Scharenspitze

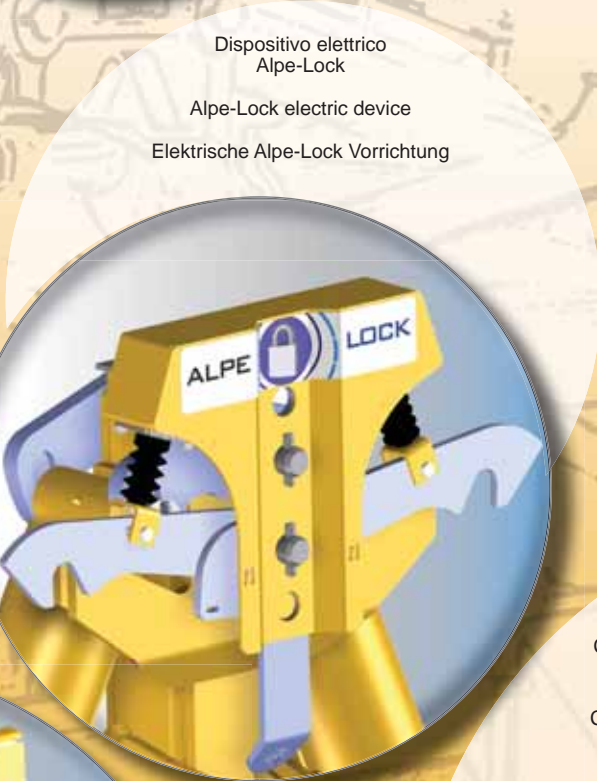

Dispositivo elettrico Alpe-Lock

Alpe-Lock electric device

Elektrische Alpe-Lock Vorrichtung

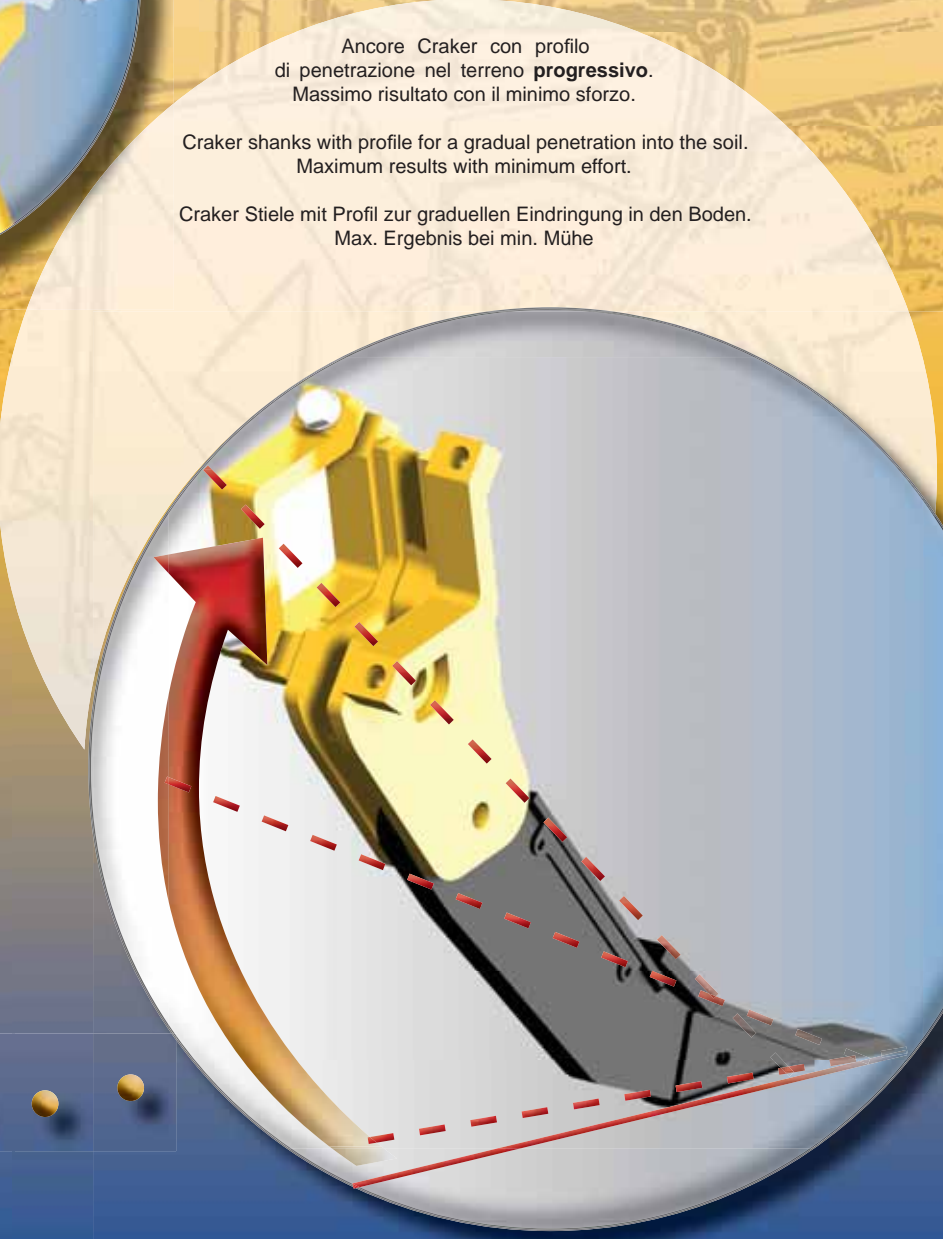

Ancore Craker con profilo di penetrazione nel terreno **progressivo**.
Massimo risultato con il minimo sforzo.

Craker shanks with profile for a gradual penetration into the soil.
Maximum results with minimum effort.

Craker Stiele mit Profil zur graduellen Eindringung in den Boden.
Max. Ergebnis bei min. Mühe



o del terreno alle massima
(5 cm.)

good flow of the soil at
(65 cm.)

en entwickelt
rde bei der
(m) zu

Ripuntatore pieghevole per trattori fino a 500HP
Foldable subsoiler for tractors up to 500HP
Klappbarer Tiefenlockerer Für Schlepper bis 500 PS

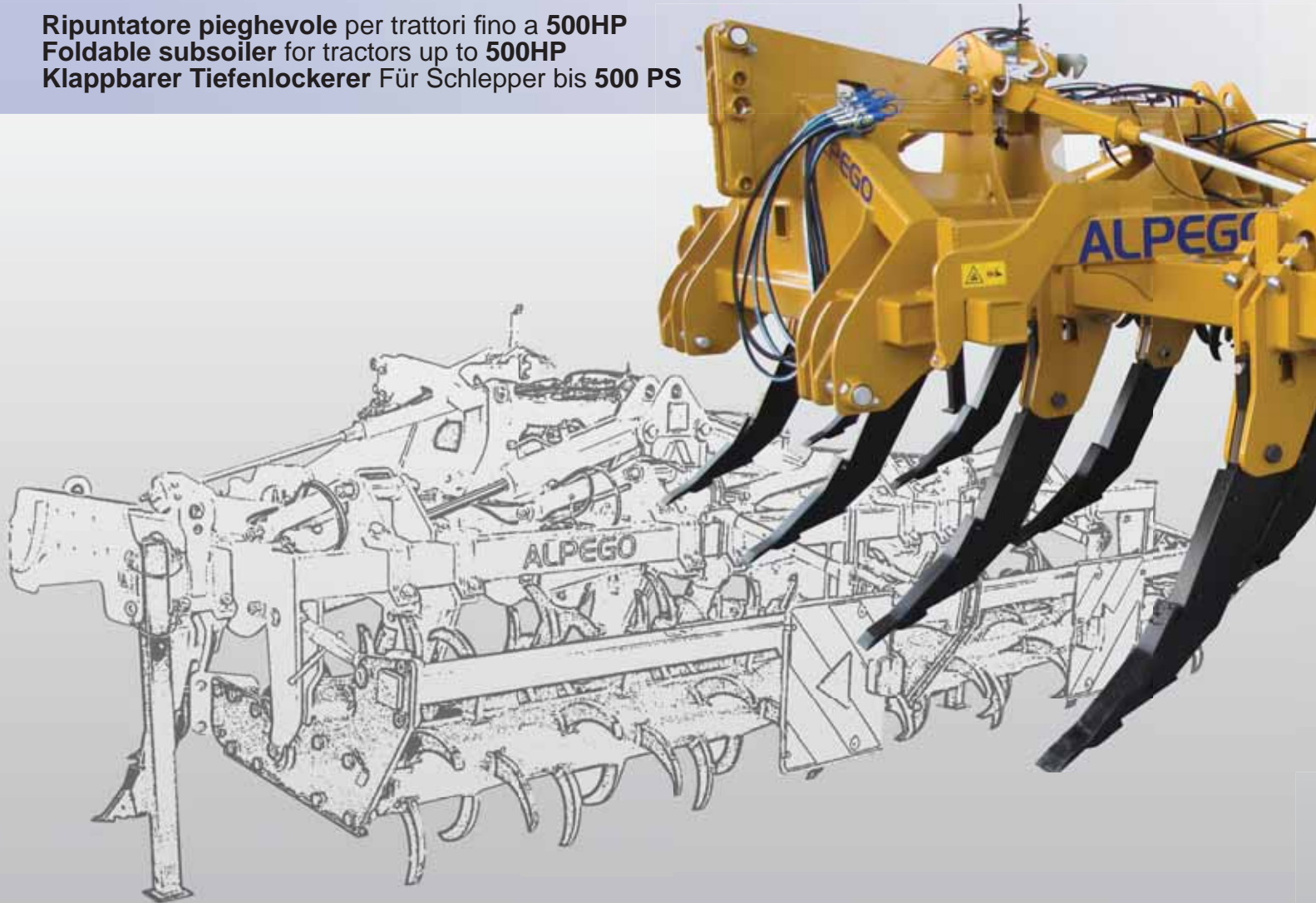

CARATTERISTICHE

- Nuovo telaio (brevettato) pieghevole idraulicamente con dimensioni di lavoro di 3,2 - 4,1 - 5,0 m
- Ingombro stradale ridotto (2,5m)
- Nuovi supporti ancora smontabili
- Nuovi rulli franter con supporti maggiorati
- Ancore con dispositivo di sicurezza a bullone
- Ancore Craker con angolo di penetrazione progressivo
- Correttore profondità di lavoro (brevettato) con parallelogramma a comando idraulico
- Attacchi al trattore 3°-4°cat. normali + USA
- Vomeri a smontaggio rapido
- Impianto idraulico per la chiusura dotato di blocco di sicurezza meccanico
- Doppia gamba di sostegno
- Tabelle fanali posteriori



FEATURES

- New (patented) hydraulically foldable frame with working widths of 3.2 - 4.1 - 5.0 m.
- Reduced transport width (2,5 m)
- New removable shank supports
- New Franter rollers with sturdier supports
- Shanks with shear-bolt safety
- Craker shanks with a gradual penetration angle
- (Patented) working depth adjuster with a hydraulically controlled parallelogram
- Hitch to tractor Cat. 3 and 4 normal + USA
- Quick-release plow tips
- Hydraulic folding circuit with a mechanical safety lock
- Double supporting stand
- Rear light boards



EIGENSCHAFTEN

- Neuer hydr. faltbare Tragrahmen (Patent) mit Arbeitsbreiten 3,2 - 4,1 - 5,0 m.
- Geringe Transportbreite (2,5 m.)
- Neue, abnehmbare Stiel-Halter
- Neue Franter-Walzen mit verstärkten Haltern
- Stiel mit Scherbolzen-Steinsicherung
- Craker Stiele mit graduelltem Eindringungswinkel
- Arbeitstiefe-Einstellvorrichtung (Patent) mit hydraulisch gesteuertem Parallelogramm
- Kuppelung an Schlepper Kat 3 u. 4 normal + USA
- Schnellwechsel-Pflügspitzen
- Hydr. Klappvorrichtung mit mechanischer Absperrung
- Doppelt-Stützfuß
- Hintere licht-tragende Tafeln

DATI TECNICI / TECHNICAL DATA / TECHNISCHE ANGABEN

MODEL	HP	mm	mm	mm	(n°)	mm	KG	KG
Mega craKer KX 320	230-500	3200	2480	650	7	450	1880	2930
Mega craKer KX 410	280-500	4100	2480	650	9	450	2220	3310
Mega craKer KX 500	300-500	5000	2480	650	11	450	2520	3730

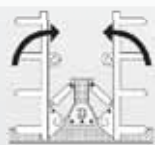

ACCESSORI / OPTIONS / ZUBEHÖR

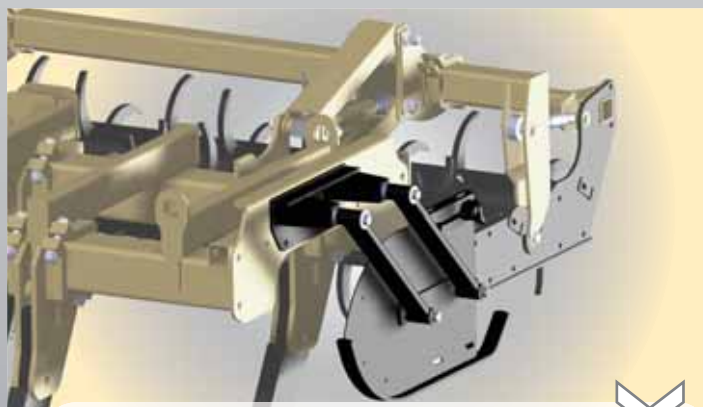

Kit contenimento zolle
Soil restraining side plates
Satz Seitenbleche zur Einschränkung der Erde



Coppia rulli franter
Pair of Franter rollers
Paar Franter Walzen



Vomere DEK
DEK Tip
DEK Pflugschar

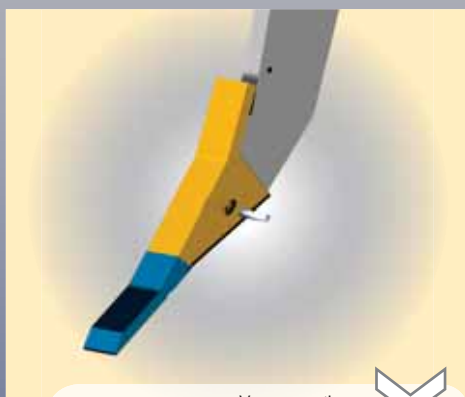

Vomere antiusura
Wearproof plow tip
Verschleissfeste Pflugschar



Esplosori ad alette
Clod-shattering fins
Schollen-zerbröckelnde Seitenmesser

ERPICI ROTANTI

Power Harrows / Kreiseleggen

Da 1.10 a 8.00 mt
Per trattori da 50 a 500HP

From 1.10 to 8.00 mt.
For tractors from 50 to 500HP

Von 1.10 bis 8.00 mt.
Für Schlepper von 50 bis 500PS



FRESATRICI

Rotary tillers / Fräsen

Da 1.60 a 4.00 mt
Per trattori da 50 a 200HP

From 1.60 to 4.00 mt.
For tractors from 50 to 200HP

Von 1.60 bis 4.00 mt.
Für Schlepper von 50 bis 200PS



SEMINATRICI

Seed-drills / Drill-Maschinen

Da 2.50 a 8.00 mt
Per trattori da 80 a 400HP

From 2.50 to 8.00 mt.
For tractors from 80 to 400HP

Von 2.50 bis 8.00 mt.
Für Schlepper von 80 bis 400PS



RIPUNTATORI

Subsoilers / Tiefenlockerer

Da 1.60 a 5.00 mt
Per trattori da 80 a 500HP

From 1.60 to 5.00 mt.
For tractors from 80 to 500HP

Von 1.60 bis 5.00 mt.
Für Schlepper von 80 bis 500PS



TRINCIATRICI

Flail mowers / Mulchgeräte

Da 1.10 a 3.20 mt
Per trattori da 40 a 160HP

From 1.10 to 3.20 mt.
For tractors from 40 to 160HP

Von 1.10 bis 3.20 mt.
Für Schlepper von 40 bis 160PS



PREPARATORE A DISCHI

Disc Harrow / Kurzscheibeneggen

Da 3.00 a 6.00 mt
Per trattori da 120 a 350HP

From 3.00 to 6.00 mt.
For tractors from 120 to 350HP

Von 3.00 bis 6.00 mt.
Für Schlepper von 120 bis 350PS



Immagine e dati inseriti nel presente catalogo non sono impegnativi e possono essere modificati in ogni momento senza obbligo di preavviso.
Illustrations, data and descriptions are not binding. The Manufacturer can modify them at any time without warning.
Die Bilder, Daten und Beschreibungen sind als unverbindlich zu betrachten. Der Hersteller darf sie zu jeder Zeit, ohne Ankündigung ändern.

H02210 - DEPLIANT "Mega Craker KX"
I-GB-DE 13/04/2012



Via Torri di Confine, 6
36053 Gambellara (VI) Italy
Tel. +39 0444646100
Fax: +39 0444646199
www.alpego.com
info@alpego.com