

SUPER CRAKER KER

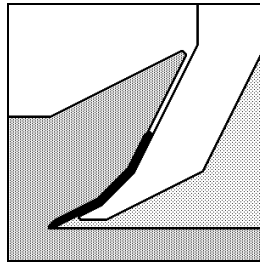

MANUAL OF USE AND MAINTENANCE

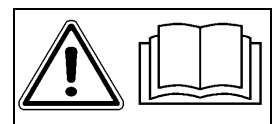

mainstkfrGB 05-2003

Carefully read this manual, before using the machine; its knowledge is essential for the safe usage of the appliance and it must be kept throughout the life time of the machine.

We thank you for purchasing our machine, you have chosen a high-quality product, guaranteed by a long experience.

Before leaving the factory, each appliance is accurately checked to guarantee it free of any defect.

If, anyhow, any defect of the materials should arise, please contact immediately your local agent.

To the purpose of constantly improving the product and to maintain it at the highest quality level we remain at your complete disposal to give you any information or explanation.



PAY ATTENTION TO THE TRIANGLE, IT MEANS DANGER



THE TERM MACHINE, REPLACES THE TRADE NAME REFERRED TO
IN THE SAID MANUAL

ALL THE DATA CONTAINED IN THE PRESENT MANUAL ARE SUPPLIED FOR
INFORMATION AND ARE NOT BINDING FOR THE MANUFACTURER WHO CAN
CHANGE THEM WITHOUT ADVANCE NOTICE

1 GENERAL INFORMATION

- 1.1 OBJECT OF THE MANUAL
- 1.2 DOCUMENTATION ACCOMPANYNG THE MACHINE
- 1.3 IDENTIFICATION OF THE MACHINE

2 GUARANTEE

3 TECHNICAL DETAILED LISTS

- 3.1 DESCRIPTION OF THE MACHINE
- 3.2 KEY ELEMENTS
- 3.3 TECHNICAL DATA TABLE

4 SAFETY RULES

- 4.1 TO USE IN SAFETY
- 4.2 CLOTHES
- 4.3 ECOLOGY
- 4.4 EXPLANATION OF THE SYMBOLS ON THE LABELS

5 INSTALLATION

- 5.1 LIFTING OF THE MACHINE
- 5.2 PREPARATION BEFORE THE USE
- 5.3 CONNECTION TO THE TRACTOR
- 5.4 CONNECTION TO THE 3 POINTS LINKAGE
- 5.5 POSITIONING OF THE LOWER ARMS

6 USE

- 6.1 USE WITH ENDOWED TRACTORS OF EFFORT CONTROLLED ON THE LIFTING
- 6.2 USE WITH UNPROVIDED TRACTORS OF EFFORT CONTROLLED ON THE LIFTING

7 EMERGENCY BOLT

8 VERIFICATIONS AND CONTROLS

- 8.1 LUBRICATION

9 UNCOUPLING AND STORAGE

10 REPLACEMENT PARTS

11 ACCESSORIES

- 11.1 KIT CONTROL SODS
- 11.2 SOIL SWEEP
- 11.3 KIT SHANK

12 SUPER CRAKER KER WITH FRANTER ROLLER



1 - GENERAL INFORMATION

1.1 OBJECT OF THE MANUAL

This handbook has been written up from the constructor of the machine and ago integrating part of the attached documentation to the machine.

The manual defines the purposes to which the machine has been produced specifying its correct usage and the limits of the same.

The constant application of the data contained in the present manual guarantees the safety of the persons using the machine, economy of operation and a longer duration of the machine.

The present manual has been divided into different paragraphs in order to facilitate the search of the various items and the consultation of the initial index.

The figures included in this manual are supplied for information even if they may greatly differ from your machine, the safety and the information, anyhow, are always guaranteed.

Following a constant development and updating policy, the manufacturer reserves the right to effect any change without advance notice



PAY ATTENTION TO THE TRIANGLE, IT MEANS DANGER

1.2 DOCUMENTATION ACCOMPANYING THE MACHINE

The machine must be accompanied by the following documentation:

- Use and maintenance manual
- CE compliance certificate
- Cardan shaft user and maintenance manual

1.3 IDENTIFICATION OF THE MACHINE

At the 3 points of connection to the tractor is placed the identification plate of the machine bearing the following data:



1-Model of the machine

2-Serial number

3-Weight

4-Constuction year

The specified weight refers to the machine provided with the heavy roller without accessories.

2- WARRANTY

At the time of delivery, check whether the machine has been damaged in transit and if all the accessories are present.

Possible claims must be made in writing within 6 days.

WARRANTY CONDITIONS

The warranty shall not apply:

- if damage is caused by incorrect use
- if the cardan shaft has not been sufficiently maintained (see maintenance manual of cardan shaft)
- if the maximum power limit allowed is exceeded (see technical data on the table 2.4)
- in case the instruction given in this manual have not been strictly followed
- in case which used non-original spare parts
- in case which the machine has carried out alteration without the consent of the Manufacturer.

3 TECHNICAL FEATURES

3.1 DESCRIPTION OF THE MACHINE

The machine comes used in order to work the land to agricultural use, this machine creates a breach in depth of the land without mix the layers represents a valid alternative to the plowing.

Its uses is concurred until the friability of the land allows to obtain one speckledness of sods such to allow the free passage of sods between the anchors without to plunge into. It is applied to equipped agricultural tractors with compatible attack to three points with the characteristics indicated in table 2.3 of the technical data.

3.2 KEY ELEMENTS:

- A) Main chassis
- B) Body still
- C) Support still
- D) Interchanging plough
- E) Protection still
- F) Attack 3° point inferior
- G) Tractor attack
- L) Wrist pins of 3°cat.
- M) Leg of support

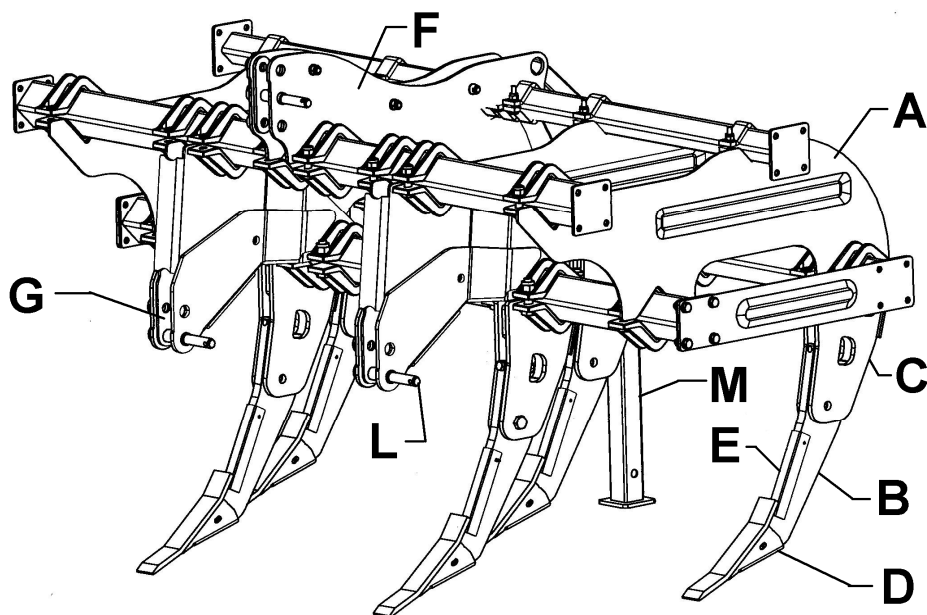

3.3 TECHNICAL DATA TABLE

model	power tractor KW	depth max. job. mm.	width of job mm.	width of transport mm.	Category attacks tractor	Anchors N°	Distance Between anchors	weight kg.
KER 5	67-132	550	2400	2200	2° 3°	5	500	810
KER 7	81-132		3300	2950		7	440	1085
KER 9	81-132		4000	3800		9	330	1397

4 - SAFETY RULES

4.1 TO USE IN SAFETY



Before the start-up, use and maintenance operation of the equipment, read carefully the use and maintenance manuals.

The manufacturer disclaims all responsibility for damages to persons, animals or things due to the non-observance of the safety rules.

It is absolutely forbidden to use the machine for purposes different from the ones expressly indicated in this booklet.

Check carefully the adhesive labels on the machine and respect their indications.

During the manoeuvres do not allow the approaching of any person or animal within the operation range of the machine.

During the work do not allow the approaching of any person or animal within the range of the sods and the stones projected by the machine.

follow 4.1 TO USE IN SAFETY



During the working pauses, switch off the engine, lay the machine on the ground and activate the tractor parking brake.

Do not work without guards.

Do not use the machine as a transportation mean for persons, animals or things.

Do not work onto grounds or places which may compromise the stability of the machine.

With respect to the on-road circulation, observe the regulations in force in each country..

Do not allow unauthorised persons to perform maintenance operations or any other kind of intervention on the machine.

Maintenance and repairing operations must be carried on in workshop fit for those purposes.

Always use original accessories and spare parts in order to comply with the requirements of the manufacturer, otherwise, any guarantee may be declined and some malfunctioning may arise impairing the safety of the machine.

4.2 CLOTHES

Always wear clothes protecting the body, without dangling parts which may get caught in the moving parts, remove watches, rings, necklaces, etc. which may represent the same danger. Long hair shall be tied.

As it is provided for by the law of the country where the machine is used, the machine operator shall wear suitable protection such as goggles, gloves, safety helmets, shoes etc.



4.3 ECOLOGY

Comply with the regulations of your own country concerning the use and the disposal of the products which are used for lubricating, maintaining and cleaning the machine ; strictly comply with the instructions listed in the packages of the products.





Comply with the laws in force also in case the machine is scrapped.



4 - SAFETY RULES

4.4 EXPLANATION OF THE SYMBOLS ON THE LABELS

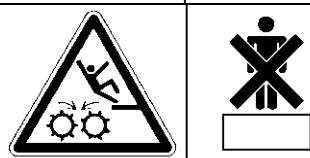
The various adhesive labels on the machine serve to signal the presence of a danger, observe them carefully and follow the indications for the safe use of the machine; they must be kept clean and readable and, if damaged, they have to be replaced.

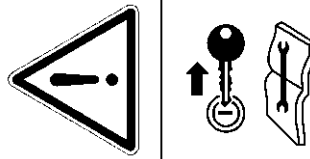
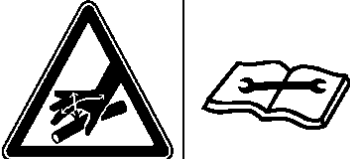
figure	code	indications
 <p><small>PRIMA DI USARE L'ATTREZZATURA E' OBBLIGATORIO LEGGERE IL LIBRETTO USO & MANUTENZIONE ED I CONSIGLI SULLA SICUREZZA ED OSSERVARE TUTTE</small></p>	D02612	Before using the equipment it is compulsory to read the user and maintenance booklet and the suggestions about safety as well as to observe all the instructions during the use.
	D02627	It Indicates the connection point for the transportation and the sheltering of the machine.
	D02613	It Indicates the shearing period during the working movements of the machine
	D02609	It indicates the absolute prohibition to get on the machine during the working operations.
	D02617	It indicates the position of a supporting leg which must always be locked while they are not used, in order to maintain the stability conditions of the machine..
	D02615	It indicates the need to switch off the tractor and to remove the start-up key during the maintenance operations .
	D02624	It indicates the danger represented by the the presence of pressurized oil in the case of a failure of the hydraulic tubes, refer to the instruction manual before carrying on any repairing operation of the hydraulic plants



5 INSTALLATION

5.1 LIFTING OF THE MACHINE

The lifting and transport operations have to be carried on with means suitable for the weight of the machine and by personnel trained for this kind of manoeuvring. Connect the machine as shown in the figure and perform the transportation, during this operation the machine **shall not be lifted for more than 200 mm** from the ground.

machine already prepared

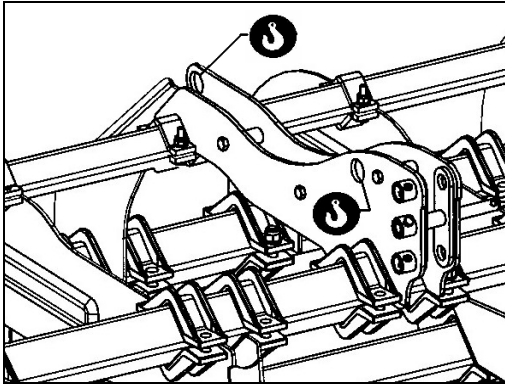

machine prepared for the shipment

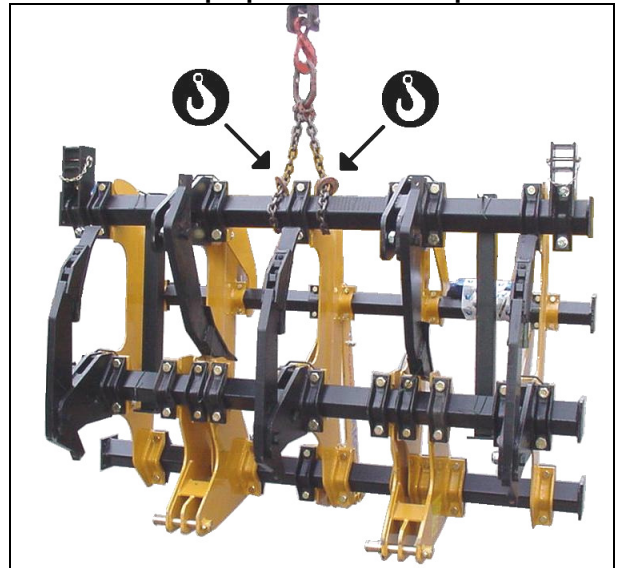

5.2 PREPARATION BEFORE THE USE

In the case in which the machine it is delivered in preparation from shipment e' necessary to remove the anchors and to mounting in the just position of job, to lock therefore the bolt of articulation **B** (only supported) and of emergency **A** (blocked). To put the leg of support in the appropriate hole and lock with the pins

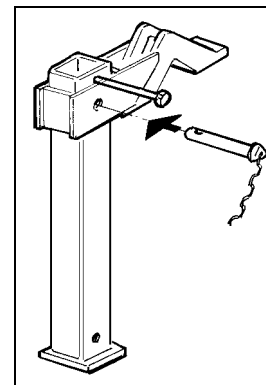
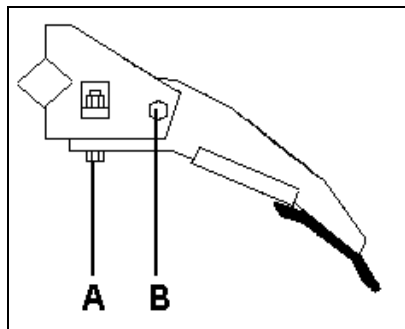

To this point to replace the machine in position of job with the rotation of 90° for means of one harness and without to raise the machine. This operation is dangerous and must be carried out with the maximum caution; to remove therefore the not attached ones and to verify the suitability of means to disposition, not to touch cargo suspended and to keep at a distance of emergency.

5.3 CONNECTION TO THE TRACTOR

The machine is predisposed for attacks of 3° category, Test especially the distribution weight on anterior axle of tractor (see technical data on the table 3.3); therefore, it may become necessary to restore the balance with the addition of suitable ballasts on the axle which has become lighter. Place the machine on level ground and reverse with the tractor at a minimum distance of 1m. from the machine.

Switch off the engine, activate the parking brake, therefore to descend from the tractor and to link the lower connections and the 3-point link.



5 INSTALLATION

5.4 CONNECTION TO THE 3 POINT LINKAGE

To proceed like indicated in figure to the connection of the inferior arms and the third party point of the tractor:

- Remove the screw and the nuts **A**
- Remove the pins **B C**
- To insert the balls of attack of the inferior arms of the tractor on the inferior mouths **D**
- Insert the pin **C**, the screw **A**
- To connect to the same the pulling way third point of the tractor threading the hinge **B** the lives and the dices **A** on one of the three holes and, to choose under the capacity of lifting of the tractor

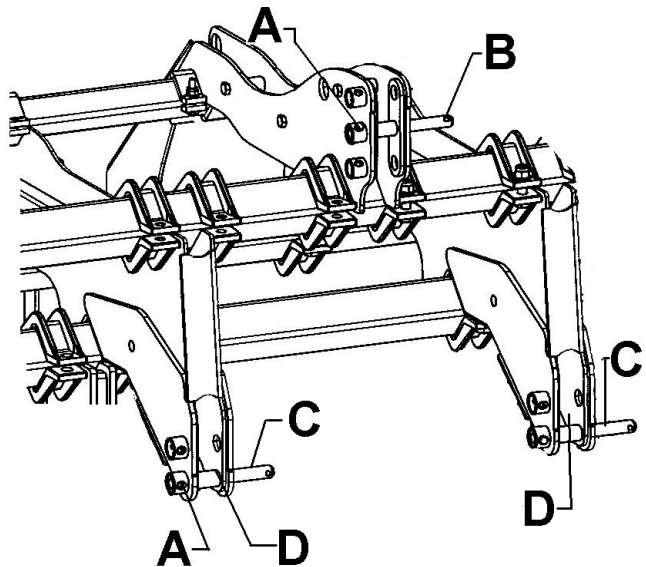

5.5 ANBRINGUNG DER KUPPLUNGEN FÜR DIE 2. ODER 3. KATEGORIE

Je nach Kategorie der Traktorkupplung werden die Kupplungszapfen, wie auf der Abbildung dargestellt ist, montiert.

Wenn die Maschine die Fabrik verläßt, sind die Kupplungen mit **825 mm** eingestellt;

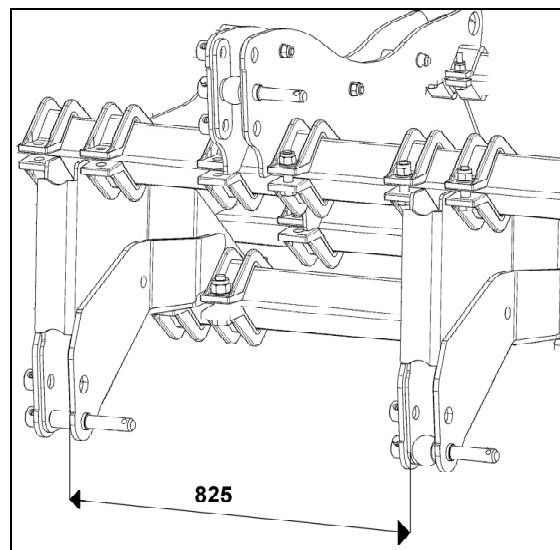

6 USE



To observe all the norms of emergency described in paragraph 4 of the manual present and to carefully consult the relative documentation to the use of the tractor.

With the machine applied to the tractor to set in action the raising therefore to raise the leg of support like indicated in figure (not to execute movements with the leg in rest position).

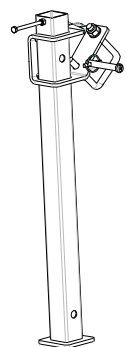

6.1 USE WITH ENDOWED TRACTORS OF EFFORT CONTROLLED ON THE LIFTING

To begin to work with the slowing speed, the anchors slowly until obtaining the wished depth of job.

To select therefore the speed of job in function of the land and present the power available holding that more the elevated speed than better advance is will turn out the effect than breach of the land.

6.2 USE WITH UNPROVIDED TRACTORS OF EFFORT CONTROLLED ON THE LIFTING

In the case in which an unprovided tractor of the device of controlled effort of the lifting is had to disposition the depth of job can be regulated with opportune supplied accessories to demand, like the FRANTER ROLLER or the posterior wheels.

These accessories support the machine and regulate the depth of job, are advised to begin the job to the minimal depth therefore to come down graded until obtaining the intentional depth of job.

7 EMERGENCY BOLT

Every anchor of the machine is equipped of device of emergency bolt that breaks off to every traction time that introduces a advanced effort to the capacity of the machine that allows to safeguard the structure of the machine from excessive efforts ; moreover in order to guarantee to the maximum the resistance of the structure e' necessary not to follow curves or changes of direction with the anchors sunk in the land, since this case come altered the values of the emergency devices.

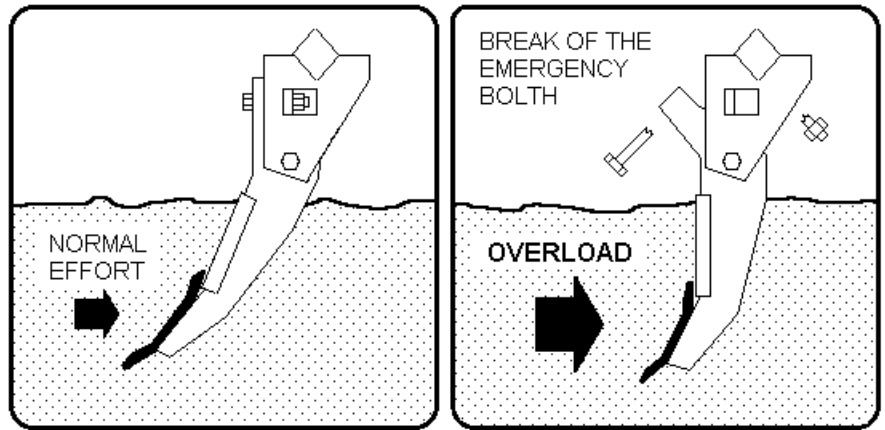

8 VERIFICATIONS AND CONTROLS

During the first **50 hours** of job it is well to control the serration of all the bolts how much the effort generated during the job creates an arrangement of the structure, eventually to tighten like from table. Later on to repeat periodically this every operation **200 hours** of job.

nominal diameter		M8	M10	M12	M14	M16	M20	M22	M24
hexagonal key	mm.	13	17	19	22	24	30	32	36
torque serration	Kgm	3	6	10	14	21	40	54	70
torque serration	Nm	30	59	98	137	205	390	350	685

8.1 LUBRICATION

The machine does not need of being lubricated in how much does not exist parts in motion, however for the complete machines of seam FRANTER ROLLER the lubrication of the supports of the two seams through the appropriate grease nipple is previewed, that it must be executed periodically **every 8/10 hours** of job.

9 UNCOUPLING AND STORAGE



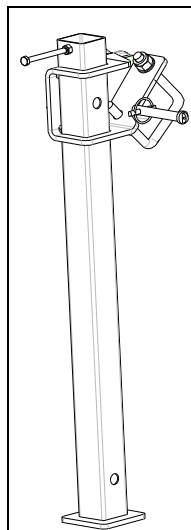

Finished the jobs lowering the leg of support and locking with the appropriate pin. The machine can be uncoupled from the tractor, **the bottom of the land must be solid in order to guarantee the stability of the machine**



10 REPLACEMENT PARTS

Present point on the tip of the anchor is particular the more subject to usury, must before be turned that it still comes corrode from the usury also the body; if the both extremities are wear and tear is necessary the substitution, for the codes of order you see table.
Others members demands as you exchange again are the protection antiusury still, and the bolts of emergency of the anchors that must exclusively like be brought back in table

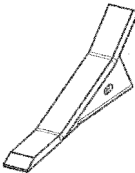
TABLE OF SPARE PARTS

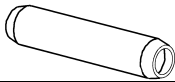
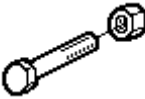
code	figure	description
E06080		VOMERE RAPIDO (largh. 70 mm.montato di serie)
D01304		PROTEZIONE ANTIUSURA (per ancora)
C04664		SPINA SPIROL D.12X60 (per vomere rapido)
CF1065		CONF.10 BULL.TE 8.8 M16x120 (per sicurezza ancore)



11 ACCESSORIES



The machine can be supplied of various accessories; to every application to keep in mind that the weights of the machine vary and therefore to verify that it does not come compromised the stability of the tractor.

TABLE ACCESSORIES AVAILABLE FOR SUPER CRAKER **KFR**

code	description	Weight Kg.
S12002	Kit control sods	106
S13001	Soil sweeps	7

11.1 KIT CONTROL SODS

It is a device that withholds sods to the inside of the width of job of the machine, preventing that these pass on the land as soon as worked or that working. Indicated junior clerk goes like in figure.

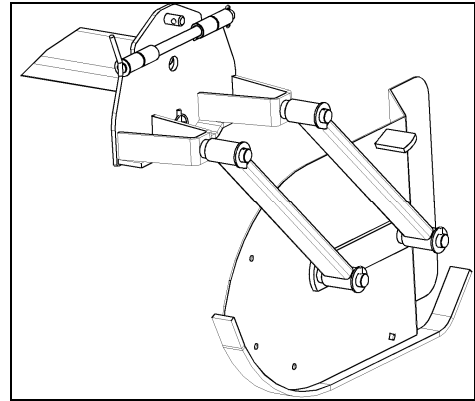

11.2 SOIL SWEEPS

This accessory allows to control the outbreak of the land in how much has varies holes of regulation ; goes directly on the anchor in place of the protection.

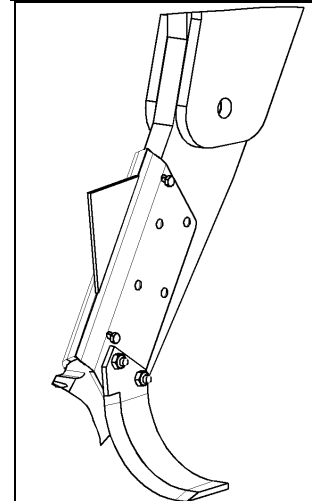

12 SUPER CRAKER KER WITH FRANTER ROLLER

This machine is the combination between a SUPER CRAKER KER and a FRANTER ROLLER these seams can be demands on request for application to a SUPER CRAKER KER. These FRANTER ROLLER behind the SUPER CRAKER, serve to support the machine and to regulate the depth of job through a series of holes, they guaranteed a good levelling of the land and a first sharpening of superficial sods. They go mounted posteriorly to the SUPER CRAKER indicated like in figure. They are constructed in measure 250 for assembly on KER 5 and 300 for assembly on KER 7.



In order to simplify the regulation now available also of the new FRANTER ROLLER with the hydraulic regulation of the depth of job,

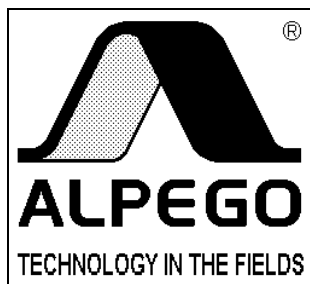

USATE SEMPRE RICAMBI ORIGINALI
EMPLOYEZ TOUJOURS LES PIÈCES DE RECHANGE ORIGINALES
IMMER DIE ORIGINAL-ERSATZTEILE VERWENDEN
ALWAYS USE ORIGINAL SPARE PARTS



ALPEGO s.r.l. Via Torri di Confine, 6 36053 GAMBELLARA - VICENZA - ITALY
tel. 0444/646100 - fax 0444/646199
E-mail: [info @ alpego.com](mailto:info@alpego.com) Internet: www.alpego.com