

Coltivatori rotanti

LP-KP



www.alpego.com

Tel +39 0444/64.61.00

Fax +39 0444/64.61.99

e-mail: info@alpego.com

ALPEGO s.p.a.

Sede Amministrativa:

Via Torri di Confine, 6 36053 GAMBELLARA (VICENZA) - ITALY

Sede Legale:

Via Giovanni e Giuseppe Cenzato, 9 36045 LONIGO (VICENZA) - ITALY

Capitale sociale €2.000.000 i.v.

Cod. Fisc. / Part. IVA IT02009840246

R.E.A. 199795/VI/1996

Reg. Imp.VI N°22374/VI/1996

N. Mecc. VI 011754

Copyright © 2009 Alpego s.p.a. ®

Tutti i diritti sono riservati. È vietata espressamente la ristampa o l'uso non autorizzato senza permesso scritto dalla Alpego s.p.a.

Tous droits réservés. Toute réimpression ou utilisation non autorisée sans la permission écrite de la Alpego s.p.a. est formellement interdite.

Alle Rechte vorbehalten. Nachdruck, Vervielfältigung und Verbreitung, auch auszugsweise, ist ohne schriftliche Genehmigung der Alpego s.p.a.

All rights reserved. Any reprinting or unauthorized use without the written permission of Alpego s.p.a. is expressly prohibited.

Todos los derechos reservados. Toda reproducción o uso no autorizado sin el consentimiento escrito de Alpego s.p.a. quedan expresamente prohibidos.

COPPIE DI INGRANAGGI DISPONIBILI				
Z1	CODICE	Z2	CODICE	CODICE COPPIA DI INGRANAGGI
19	D03816	35	D03815	S08019 Z=19/35
21	D03820	33	D03819	S08016 Z=21/33
24	D03826	30	D03825	S08017 Z=24/30
25	D03828	29	D03827	S08018 Z=25/29 **
26	D03812	28	D03811	S08015 Z=26/28
28	D03811	26	D03812	S08015 Z=28/26
29	D03827	25	D03828	S08018 Z=29/25
30	D03825	24	D03826	S08017 Z=30/24
33	D03819	21	D03820	S08016 Z=33/21

** = MONTATA DI SERIE

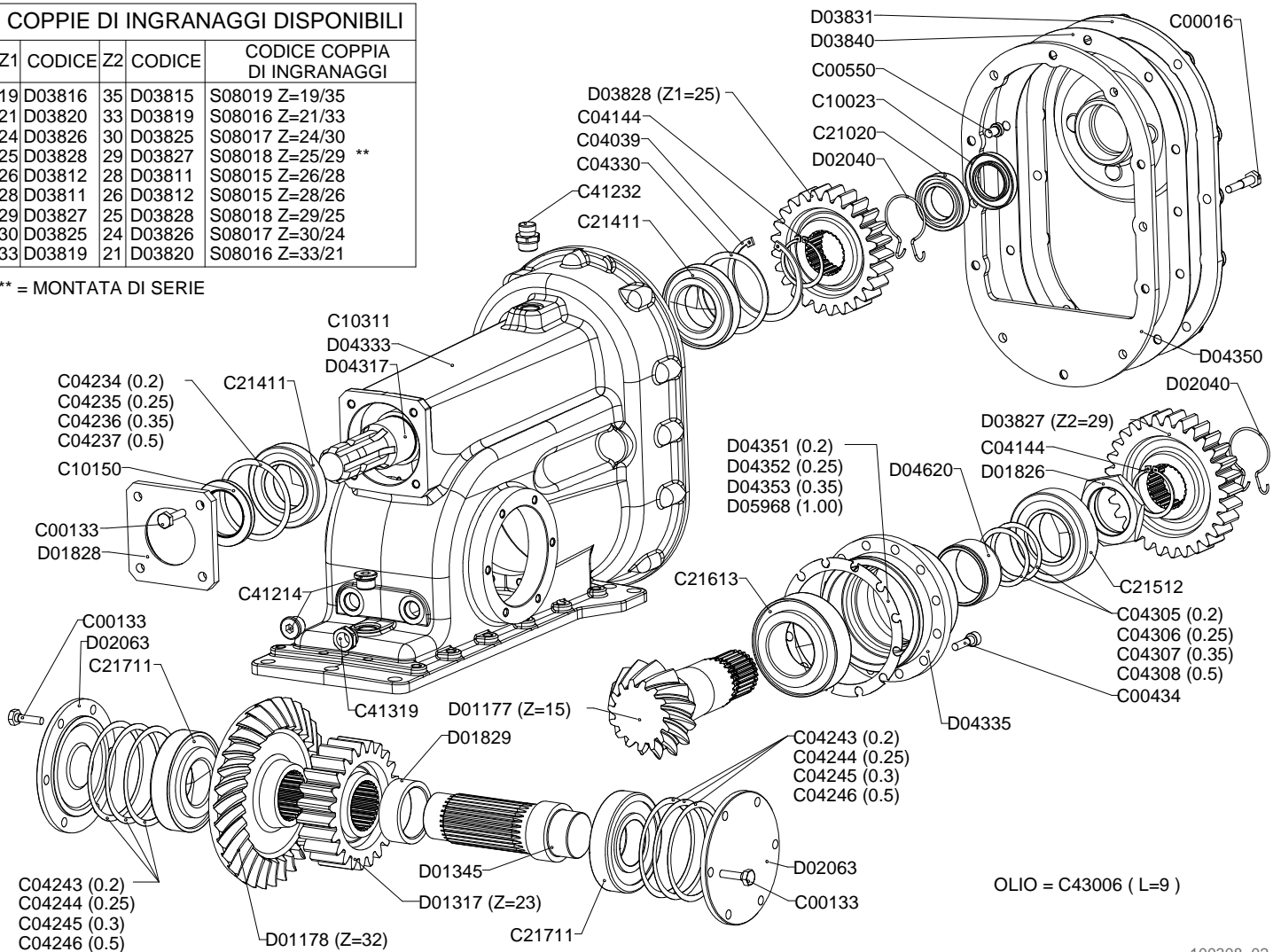

OLIO = C43006 (L=9)



Testa cambio
Gear box head
Tete boite
Wechselgetriebe

Drawing Code: **100308_2**

Accessories:

N°	Code	Old.	Descrizione / Description	GB	FR	D	E
#	M80A00013	C00016	VITE TE 88 PG FP M10X45 ZINC UNI 5737	SCREW	VIS	SCHRAUBE	TORNILLO
#	M80A00121	C00133	VITE TE 88 PG FT M10X35 ZINC UNI 5739	SCREW	VIS	SCHRAUBE	TORNILLO
#	M80A00247	C00434	VITE TCEI PG M10X35 ZINC UNI 5931	SCREW	VIS	SCHRAUBE	TORNILLO
#	M80A00270	C00550	VITE TCEI 8.8 T/RIB. M10X16 DIN7984 ZINC	SCREW	VIS	SCHRAUBE	TORNILLO
#	MA0A00014	C04039	SEEGER FORO D.100 UNI 7437	SEEGER	SEEGER	SEEGER	SEEGER
#	MA0A00044	C04144	SEEGER ALBERO D.54 UNI 7435	SEEGER	SEEGER	SEEGER	SEEGER
#	MA5A00034	C04234	SPESSORE REG. 85.3X99.8X0.2	THICKNESS	CALES	DICKE	ESPEJOR
#	MA5A00035	C04235	SPESSORE REG. 85.3X99.8X0.25	THICKNESS	CALES	DICKE	ESPEJOR
#	MA5A00036	C04236	SPESSORE REG. 85.3X99.8X0.35	THICKNESS	CALES	DICKE	ESPEJOR
#	MA5A00037	C04237	SPESSORE REG. 85.3X99.8X0.5	THICKNESS	CALES	DICKE	ESPEJOR
#	MA5A00043	C04243	SPESSORE REG. 105.5X119.5X0,2	THICKNESS	CALES	DICKE	ESPEJOR
#	MA5A00044	C04244	SPESSORE REG. 105.5X119.5X0,25	THICKNESS	CALES	DICKE	ESPEJOR
#	MA5A00045	C04245	SPESSORE REG. 105.5X119.5X0,3	THICKNESS	CALES	DICKE	ESPEJOR
#	MA5A00046	C04246	SPESSORE REG. 105.5X119.5X0,5	THICKNESS	CALES	DICKE	ESPEJOR
#	MA5A00096	C04305	SPESSORE REG. 60X72X0.20	THICKNESS	CALES	DICKE	ESPEJOR
#	MA5A00097	C04306	SPESSORE REG. 60X72X0.25	THICKNESS	CALES	DICKE	ESPEJOR
#	MA5A00098	C04307	SPESSORE REG. 60X72X0.35	THICKNESS	CALES	DICKE	ESPEJOR
#	MA5A00099	C04308	SPESSORE REG. 60X72X0.5	THICKNESS	CALES	DICKE	ESPEJOR
#	MA5A00106	C04330	RALLA REG. 85.3X99.7X2	FIFTH WHEEL	RONDELLE	DREHPLATTE	RAYA
#	H00A00011	C10023	PARAOLIO BA D.40X68X10	SEALING RING	JOINT SPI	OELABDICHTUNG	PARAOLIO
#	H00A00063	C10150	PARAOLIO BASL D.55X80X8	SEALING RING	JOINT SPI	OELABDICHTUNG	PARAOLIO
#	H00A00083	C10311	CAPPELOTTO D.26X7	PLASTIC GUARD	BACHE	KUNSTSTOFF-DECKEL	SOMBRERETE
#	M20A00011	C21020	CUSCINETTO 6008 40X68X15	BEARING	ROULEMENT	KUGELLAGER	COJINETE
#	M20A00063	C21411	CUSCINETTO 30211 55X100X22,75	BEARING	ROULEMENT	KUGELLAGER	COJINETE
#	M20A00075	C21512	CUSCINETTO 32212 60X110X29,75	BEARING	ROULEMENT	KUGELLAGER	COJINETE
#	M20A00085	C21613	CUSCINETTO 33213 65X120X41	BEARING	ROULEMENT	KUGELLAGER	COJINETE
#	M20A00091	C21711	CUSCINETTO 30311 55X120X31,5	BEARING	ROULEMENT	KUGELLAGER	COJINETE
#	H45A00007	C41214	TAPPO + GUARNIZIONE SCARICO M22X1,5 (41 B)	PLUG	BOUCHON	STOEPSSEL	ENCHUFE
#	H65A00004	C41232	TAPPO + GUARNIZ SFIATO M22X1,5 (31.A) LABI	PLUG	BOUCHON	STOEPSSEL	ENCHUFE
#	H60A00006	C41319	SPIA LIVELLO GLASS M22X1.5	LIGHT	LUMIERE	WARNLAMPE	INDICADOR
#							
#	M40A00003	D01177	PIGNONE CONICO ELIC. Z=15 DE/LE	PINION	PIGNON	RITZEL	PIÑON
#	M40A00004	D01178	CORONA CONICA ELIC. Z=32 DF/LE	CROWN	COURONNE	KRONE	CORONA
#	M40A00009	D01317	INGRANAGGIO Z=23 LE-LH-FH	GEAR	ENGRENAGES	ZAHNRAEDER	ENGRANAJE
#	M45A00011	D01345	ALBERO PORTA CORONA LE	SHAFT	ARBRE	WELLE	EJE
#	M95A00023	D01826	GHIERA CON COLLARE M60x1,5	METAL RING	RONDELLE	METALL-RING	RUEDA
#	C15A00091	D01828	COPERCHIO INGRESSO LE/DF 120X120***	LID	COUVERCLE	DECKEL	TAPA
#	C15A00092	D01829	DIST. D.75 D.60 L.26***	SPACER	ENTRETOISE	ABSTANDSTUECK	ESPACIADORES
#	MF5A00013	D02040	MOLLA DI RITEGNO INGR.LE/DF CAVA D.51.5	SPRING	RESSORT	FEDER	MUELLE
#	C15A00123	D02063	COPERCHIO D.160 CORONA LE***	LID	COUVERCLE	DECKEL	TAPA
#	M40A00058	D03811	INGRAN. CAMBIO CS Z=28 (COPPIA 26/28)***	GEAR	ENGRENAGE	ZAHNRAEDER	ENGRANAJE
#	M40A00059	D03812	INGRAN. CAMBIO CS Z=26 (COPPIA 26/28)***	GEAR	ENGRENAGE	ZAHNRAEDER	ENGRANAJE
#	M40A00060	D03815	INGRAN. CAMBIO CS Z=35 (COPPIA 35/19)***	GEAR	ENGRENAGE	ZAHNRAEDER	ENGRANAJE
#	M40A00061	D03816	INGRAN. CAMBIO CS Z=19 (COPPIA 35/19)***	GEAR	ENGRENAGE	ZAHNRAEDER	ENGRANAJE
#	M40A00062	D03819	INGRAN. CAMBIO CS Z=33 (COPPIA 33/21)***	GEAR	ENGRENAGE	ZAHNRAEDER	ENGRANAJE
#	M40A00063	D03820	INGRAN. CAMBIO CS Z=21(COPPIA 33/21)***	GEAR	ENGRENAGE	ZAHNRAEDER	ENGRANAJE
#	M40A00066	D03825	INGRAN. CAMBIO CS Z=30 (COPPIA 30/24)***	GEAR	ENGRENAGE	ZAHNRAEDER	ENGRANAJE
#	M40A00067	D03826	INGRAN. CAMBIO CS Z=24 (COPPIA 30/24)***	GEAR	ENGRENAGE	ZAHNRAEDER	ENGRANAJE
#	M40A00068	D03827	INGRAN. CAMBIO CS Z=29 (COPPIA 29/25)***	GEAR	ENGRENAGE	ZAHNRAEDER	ENGRANAJE

Copyright © 2009 Alpego s.p.a. ®

Tutti i diritti sono riservati. È vietata espressamente la ristampa o l'uso non autorizzato senza permesso scritto dalla Alpego s.p.a.
 Tous droits réservés. Toute réimpression ou utilisation non autorisée sans la permission écrite de la Alpego s.p.a. est formellement interdite
 Alle Rechte vorbehalten. Nachdruck, Vervielfältigung und Verbreitung, auch auszugsweise, ist ohne schriftliche Genehmigung der Alpego s.p.a.
 All rights reserved. Any reprinting or unauthorized use without the written permission of Alpego s.p.a. is expressly prohibited
 Todos los derechos reservados. Toda reproducción o uso no autorizado sin el consentimiento escrito de Alpego s.p.a. quedan expresamente prohibidos

22/05/2014

COPPIE DI INGRANAGGI DISPONIBILI				
Z1	CODICE	Z2	CODICE	CODICE COPPIA DI INGRANAGGI
19	D03816	35	D03815	S08019 Z=19/35
21	D03820	33	D03819	S08016 Z=21/33
24	D03826	30	D03825	S08017 Z=24/30
25	D03828	29	D03827	S08018 Z=25/29 **
26	D03812	28	D03811	S08015 Z=26/28
28	D03811	26	D03812	S08015 Z=28/26
29	D03827	25	D03828	S08018 Z=29/25
30	D03825	24	D03826	S08017 Z=30/24
33	D03819	21	D03820	S08016 Z=33/21

** = MONTATA DI SERIE

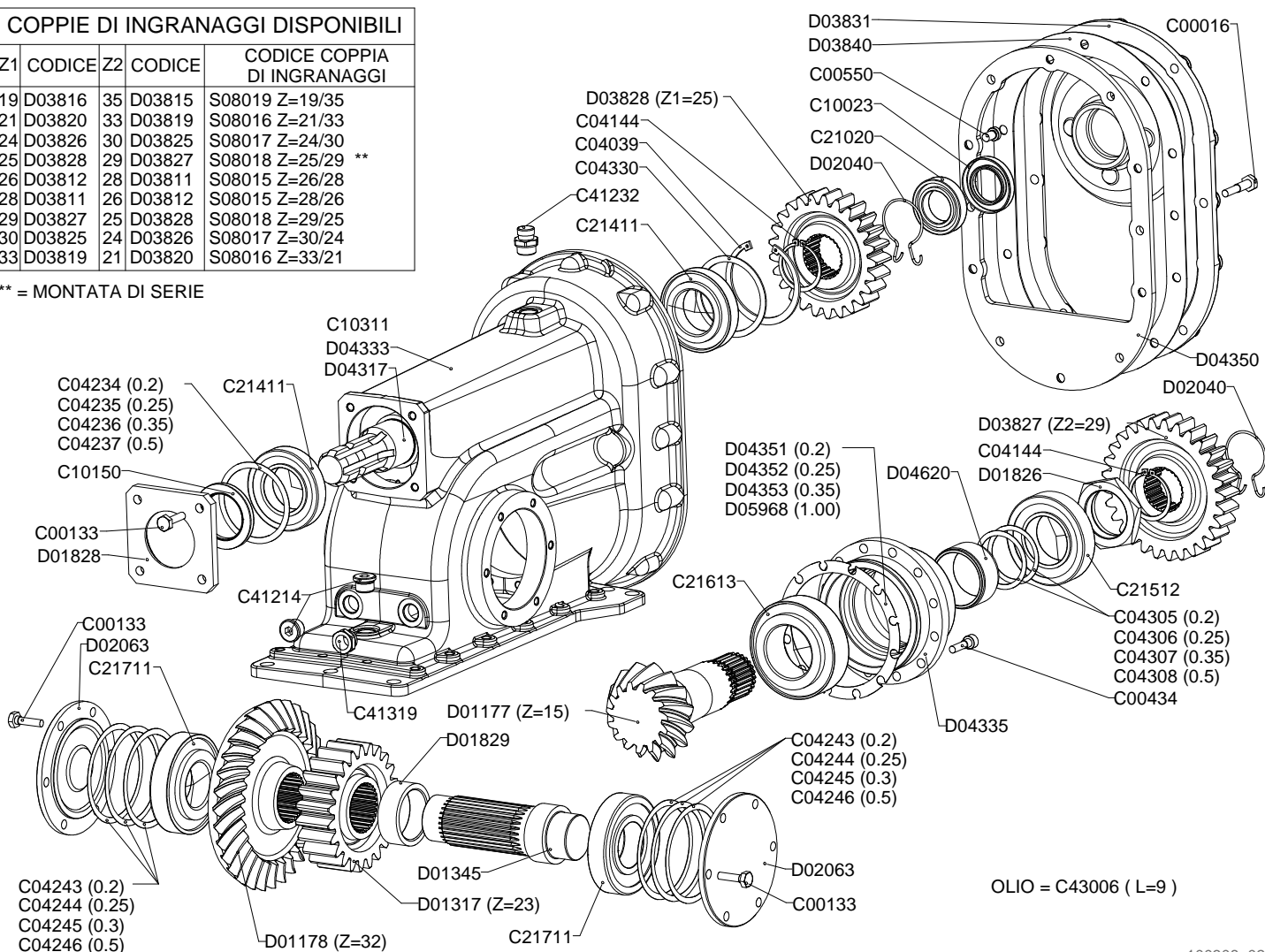



Testa cambio

Gear box head

Tete boite

Wechselgetriebe

Drawing Code:

100308_2

Accessories:

N°	Code	Old.	Descrizione / Description
#	M40A00069	D03828	INGRAN. CAMBIO CS Z=25 (COPPIA 29/25)***
#	C15A00301	D03831	COPERCHIO POSTERIORE CS 120/190
#	H30A00017	D03840	GUARNIZ. COPERCHIO CAMBIO CS/CL
#	M45A00046	D04317	ALBERO INGRESSO T130/T190
#	C15A00345	D04333	SCATOLA CAMBIO T130/T190
#	C15A00347	D04335	MOZZO PORTA PIGNONE T130/T190
#	C15A00350	D04350	PARETE COPERCHIO T130/T190
#	MA5A00112	D04351	SPESSORE REG. 0.20 PIGNONE T130/T190
#	MA5A00113	D04352	SPESSORE REG. 0.25 PIGNONE T130/T190
#	MA5A00114	D04353	SPESSORE REG. 0.35 PIGNONE T130/T190
#	C15A00371	D04620	DISTANZ. PIGNONE CAMBIO T-190***
#	MA5A00115	D05968	SPESSORE REG. 1MM PIGNONE T130/T190
#	SA0A00019	S08015	COPPIA INGRANAGGI 26/28 CS
#	SA0A00020	S08016	COPPIA INGRANAGGI 21/33 CS
#	SA0A00021	S08017	COPPIA INGRANAGGI 24/30 CS
#	SA0A00022	S08018	COPPIA INGRANAGGI 25/29 CS
#	SA0A00023	S08019	COPPIA INGRANAGGI 19/35 CS

GB	FR	D	E
GEAR	ENGRENAGE	ZAHNRAEDER	ENGRANAJE
LID	COUVERCLE	DECKEL	TAPA
GASKET	GARNITURE	DICHTUNG	GUARNICION
SHAFT	ARBRE	WELLE	EJE
BOX	BOITE	SCHACTEL	RECUADRO
HUB	ESSIEU	NABE	MAZO
WALL	MUR	WAND	PARED
THICKNESS	CALES	DICKE	ESPEJOR
THICKNESS	CALES	DICKE	ESPEJOR
THICKNESS	CALES	DICKE	ESPEJOR
SPACER	ENTRETOISE	ABSTANDSTUECK	ESPACIADORES
THICKNESS	CALES	DICKE	ESPEJOR
PAIR	PAIRE	PAAR	PAREJA/PAR
PAIR	PAIRE	PAAR	PAREJA/PAR
PAIR	PAIRE	PAAR	PAREJA/PAR
PAIR	PAIRE	PAAR	PAREJA/PAR
PAIR	PAIRE	PAAR	PAREJA/PAR

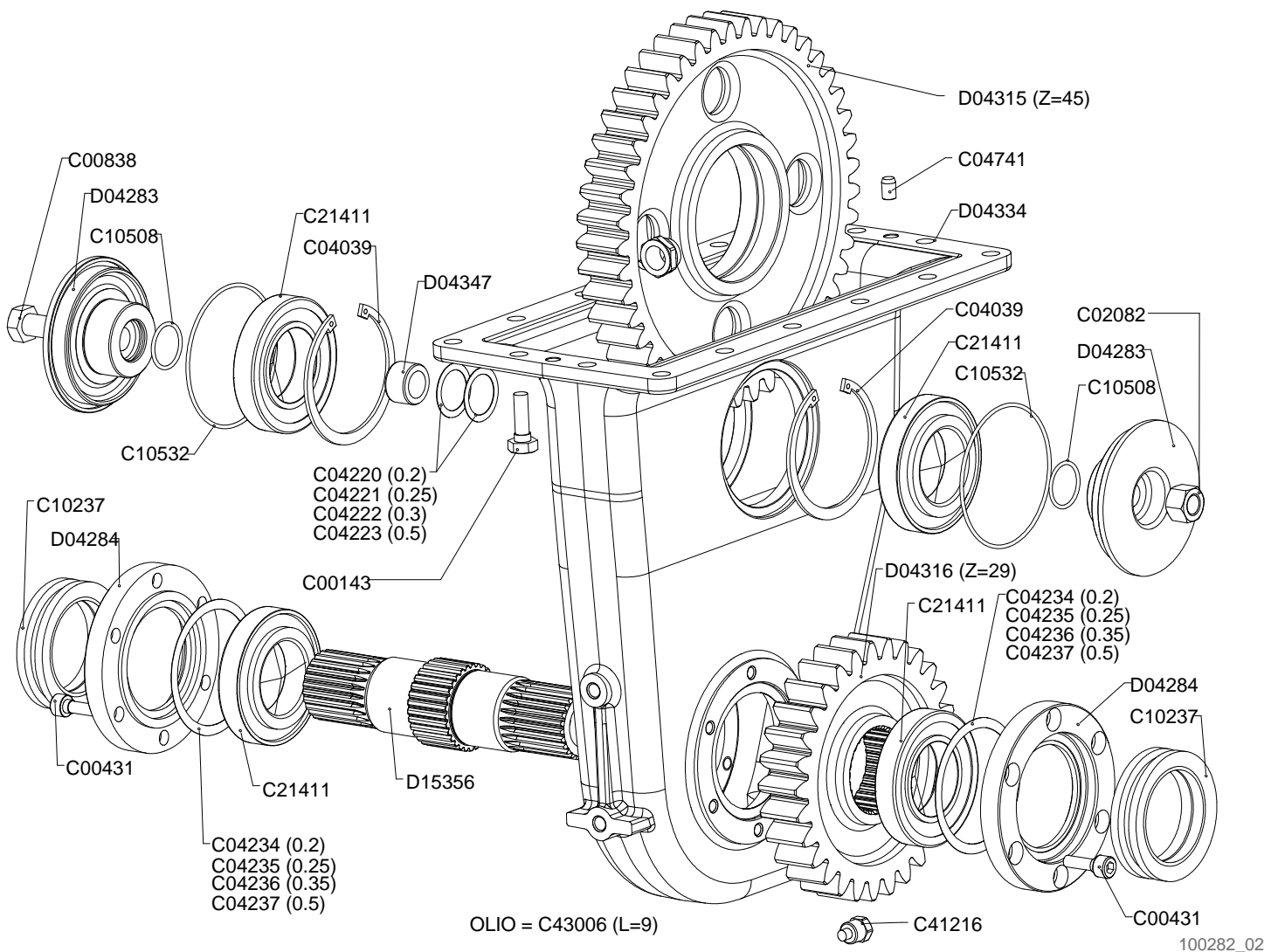



Cascata

Lower transmission

Transmission inferieur

Unter getriebe

Drawing Code:

100282_2

Accessories:

N°	Code	Old.	Descrizione / Description	GB	FR	D	E
#	M80A00130	C00143	VITE TE 88 PG FT M12X35 ZINC UNI 5739	SCREW	VIS	SCHRAUBE	TORNILLO
#	M80A00244	C00431	VITE TCEI PG M10X30 ZINC UNI 5931	SCREW	VIS	SCHRAUBE	TORNILLO
#	M80A00332	C00838	VITE TE 12.9 M16X1,5X65 F28/32 (T.TONDA)	SCREW	VIS	SCHRAUBE	TORNILLO
#	M85A00022	C02082	DADO ALTO 10 PF M16X1,5 5587	NUT	BOULONS	NUT	DADO
#	MA0A00014	C04039	SEEGER FORO D.100 UNI 7437	SEEGER	SEEGER	SEEGER	SEEGER
#	MA5A00020	C04220	SPESSORE REG. 30X40X0,2	THICKNESS	CALES	DICKE	ESPESOR
#	MA5A00021	C04221	SPESSORE REG. 30X40X0,25	THICKNESS	CALES	DICKE	ESPESOR
#	MA5A00022	C04222	SPESSORE REG. 30X40X0,3	THICKNESS	CALES	DICKE	ESPESOR
#	MA5A00023	C04223	SPESSORE REG. 30X40X0,5	THICKNESS	CALES	DICKE	ESPESOR
#	MA5A00034	C04234	SPESSORE REG. 85.3X99.8X0.2	THICKNESS	CALES	DICKE	ESPESOR
#	MA5A00035	C04235	SPESSORE REG. 85.3X99.8X0.25	THICKNESS	CALES	DICKE	ESPESOR
#	MA5A00036	C04236	SPESSORE REG. 85.3X99.8X0.35	THICKNESS	CALES	DICKE	ESPESOR
#	MA5A00037	C04237	SPESSORE REG. 85.3X99.8X0.5	THICKNESS	CALES	DICKE	ESPESOR
#	MB0A00079	C04741	SPINA CILINDRICA D.10X16 DIN 6325	SOCKET	GOUPILLE	STECKER	PASADOR
#	H25A00001	C10237	TENUTA MECCANICA D.95.4 D.67X23	SEAL	GARNITURE	DICHTUNG	SELLO
#	H05A00011	C10508	ANELLO OR 3118 D.INT.29.82X2,62	RING	AMORTISSEUR	RING	ANILLO
#	H05A00034	C10532	ANELLO OR 3400 D.INT.101,27x2,62	RING	AMORTISSEUR	RING	ANILLO
#	M20A00063	C21411	CUSCINETTO 30211 55X100X22,75	BEARING	ROULEMENT	KUGELLAGER	COJINETE
#	H45A00009	C41216	TAPPO CONICO M16X1,5 MAGNET.8X18 CH-17	PLUG	BOUCHON	STOEPSSEL	ENCHUFE
#							
#	C15A00339	D04283	BOTTONE PERNO INTERMEDIO C90 ***	PUSH-BOTTON	BOUTONS	DRUCK-KNOPF	BOTON
#	C15A00340	D04284	COPERCHIO ALBERO USCITA C90***	LID	COUVERCLE	DECKEL	TAPA
#	M40A00077	D04315	INGRANAGGIO Z=45 C130	GEAR	ENGRENAGES	ZAHNRAEDER	ENGRANAJE
#	M40A00078	D04316	INGRANAGGIO Z=29 C130	GEAR	ENGRENAGES	ZAHNRAEDER	ENGRANAJE
#	C15A00346	D04334	SCATOLA CASCATA C130	BOX	BOITE	SCHACTEL	RECUADRO
#	C15A00349	D04347	DIST. D.30 d.23,7 L.18,5 ***	SPACER	ENTRETOISE	ABSTANDSTUECK	ESPACIADORES
#	M45A00075	D15356	ALBERO USCITA C90/130 2A VERSIONE	SHAFT	ARBRE	WELLE	EJE

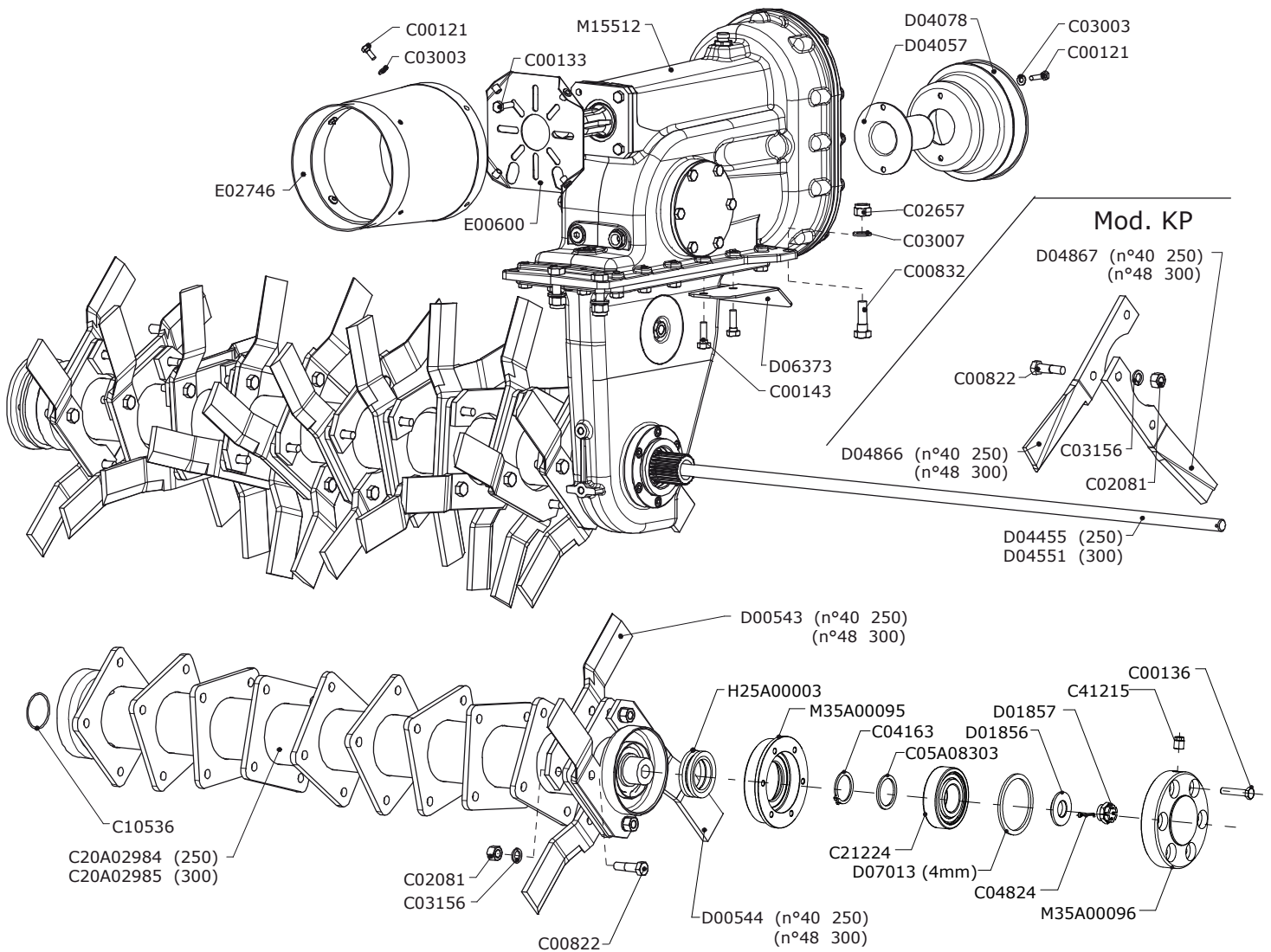



Trasmissione (TM)

Transmission (TM)

Transmission (TM)

Getriebe (TM)

Drawing Code:

100422_2

Accessories:

N°	Code	Old.	Descrizione / Description	GB	FR	D	E
#	M80A00110	C00121	VITE TE 88 PG FT M8X20 ZINC UNI 5739	SCREW	VIS	SCHRAUBE	TORNILLO
#	M80A00121	C00133	VITE TE 88 PG FT M10X35 ZINC UNI 5739	SCREW	VIS	SCHRAUBE	TORNILLO
#	M80A00124	C00136	VITE TE 88 PG FT M10X50 ZINC UNI 5739	SCREW	VIS	SCHRAUBE	TORNILLO
#	M80A00130	C00143	VITE TE 88 PG FT M12X35 ZINC UNI 5739	SCREW	VIS	SCHRAUBE	TORNILLO
#	M80A00323	C00822	VITE TE 10.9 M14X1,5X50 F23	SCREW	VIS	SCHRAUBE	TORNILLO
#	M80A00325	C00832	VITE TE 12.9 M16X1,5X50 F25/28 (T.TONDA)	SCREW	VIS	SCHRAUBE	TORNILLO
#	M85A00021	C02081	DADO ALTO 10 PF M14,X1,5 5587	NUT	BOULONS	NUT	DADO
#	M85A00089	C02657	DADO AUTOBLOC ALTO 8 M16X1,5 H=18 UNI 7473	NUT	BOULONS	NUT	DADO
#	M90A00005	C03003	RONDELLA PIANA D.8,4 DIN125-A ZINC.	WASHER	RONDELLE	UNTERLEGSCHLEIBE	ARANDELLA
#	M90A00010	C03007	RONDELLA PIANA D.17 DIN125-A ZINC.	WASHER	RONDELLE	UNTERLEGSCHLEIBE	ARANDELLA
#	M90A00046	C03156	RONDELLA GROWER RINF. D.14 ASA B27	WASHER	RONDELLE	UNTERLEGSCHLEIBE	ARANDELLA
#	MA0A00050	C04163	SEEGER ALBERO D.45X2,5 UNI 7436	SEEGER	SEEGER	SEEGER	SEEGER
#	MB5A00011	C04824	COPPIGLIA D.4X40	COTTER PIN	GOUPILLE	SPLINT	COPPIGLIA
#	C05A08303		RALLA D.56X45,2 SP.3MM NASTRO BLU	FIFTH WHEEL	RONDELLE	DREHPLATTE	RAYA
#	H05A00046	C10536	ANELLO OR 3206 D.INT.52.07X2.62	RING	AMORTISSEUR	RING	ANILLO
#	C20A02984		ROTORE PORTAZAPPE LP/KP-250 T.FRONTALE 10 F.	ROTOR	ROTOR	ROTOR	ROTOR
#	C20A02985		ROTORE PORTAZAPPE LP/KP-300 T.FRONTALE 12 F.	ROTOR	ROTOR	ROTOR	ROTOR
#	M20A00047	C21224	CUSCINETTO 6309 45X100X25	BEARING	ROULEMENT	KUGELLAGER	COJINETE
#	H45A00008	C41215	TAPPO CONICO M16X1,5 8X18 CH17 (11/C)	PLUG	BOUCHON	STOEPSSEL	ENCHUFE
#	MK0A00003	D00543	LAMA DESTRA LD/LP INTER.130 FORI 15	METAL PLATE	LAME	METALL-PLATTE	CUCHILLA
#	MK0A00005	D00544	LAMA SINISTRA LD/LP INTER.130 FORI 15	METAL PLATE	LAME	METALL-PLATTE	CUCHILLA
#	C15A00102	D01856	RONDELLA SPECIALE LD3 CON BATTUTA D.45*	WASHER	RONDELLE	UNTERLEGSCHLEIBE	ARANDELLA
#	M85A00104	D01857	DADO CORONA SPECIALE M20X1,5***	NUT	BOULONS	NUT	DADO
#	G10A00043	D04057	PROT. P.D.F. DE56X105 FLANGIA D.120	PROTECTION	PROTECTION	SCHUTZ	PROTECCIÓN
#	G10A00044	D04078	PROT. DE200X110 2 FORI D.9X105	PROTECTION	PROTECTION	SCHUTZ	PROTECCIÓN
#	C15A00358	D04455	TIRANTE ROTORE FM/FP-250 D.20X2488	TIE ROD	TIRANT	ZUGSTANGE	TIRANTE
#	C15A00369	D04551	TIRANTE ROTORE FM/FP-300 D.20X2957	TIE ROD	TIRANT	ZUGSTANGE	TIRANTE
#	MK0A00079	D04866	DENTE DESTRO ROTOPIK KP	TOOTH	DENT	ZAHN	DIENTE
#	MK0A00081	D04867	DENTE SINISTRO ROTOPIK KP	TOOTH	DENT	ZAHN	DIENTE
#	C10A01754	D06373	CHIUSURA INFERIORE CAMBIO/COFANO FPA 3MM	GATE	FERMETURE	VERSCHLUSS	CIERRE
#	C05A05450	D07013	SPESSORE REG. 85,3x99,7xsp4mm	THICKNESS	CALES	DICKE	ESPESOR
#	C20A00034	E00600	FONDELLO PROTEZIONE COMPLETO	BOTTOM	FOND	BODEN	FONDO
#	G10A00071	E02746	PROTEZIONE CARDANO PROLUNGATA	PROTECTION	PROTECTION	SCHUTZ	PROTECCIÓN
#	H25A00003		TENUTA MECCANICA D.76,2 D.50,5X22,5	SEAL	GARNITURE	DICHTUNG	SELLO
#	M65A00143	M15512	CAMBIO T+C 130 Z=25/29 (1000=320) RINF.	GEAR SHIFT	BOITE DE VITESSE	WECHSELGETRIEBE	CAMBIO
#	M35A00095		SUPPORTO ESTERNO LD3 T.FRONTALE	SUPPORT	SUPPORT	STUTZE	APOYO
#	M35A00096		FLANGIA COPERCHIO SUPP.LD3 T.FRONTALE	FLANGE	FLANC	FLANSCH	FLANGE

Copyright © 2009 Alpego s.p.a. ®

Tutti i diritti sono riservati. È vietata espressamente la ristampa o l'uso non autorizzato senza permesso scritto dalla Alpego s.p.a.

Tous droits réservés. Toute réimpression ou utilisation non autorisée sans la permission écrite de la Alpego s.p.a. est formellement interdite

Alle Rechte vorbehalten. Nachdruck, Vervielfältigung und Verbreitung, auch auszugsweise, ist ohne schriftliche Genehmigung der Alpego s.p.a.

All rights reserved. Any reprinting or unauthorized use without the written permission of Alpego s.p.a. is expressly prohibited

Todos los derechos reservados. Toda reproducción o uso no autorizado sin el consentimiento escrito de Alpego s.p.a. quedan expresamente prohibidos

22/05/2014

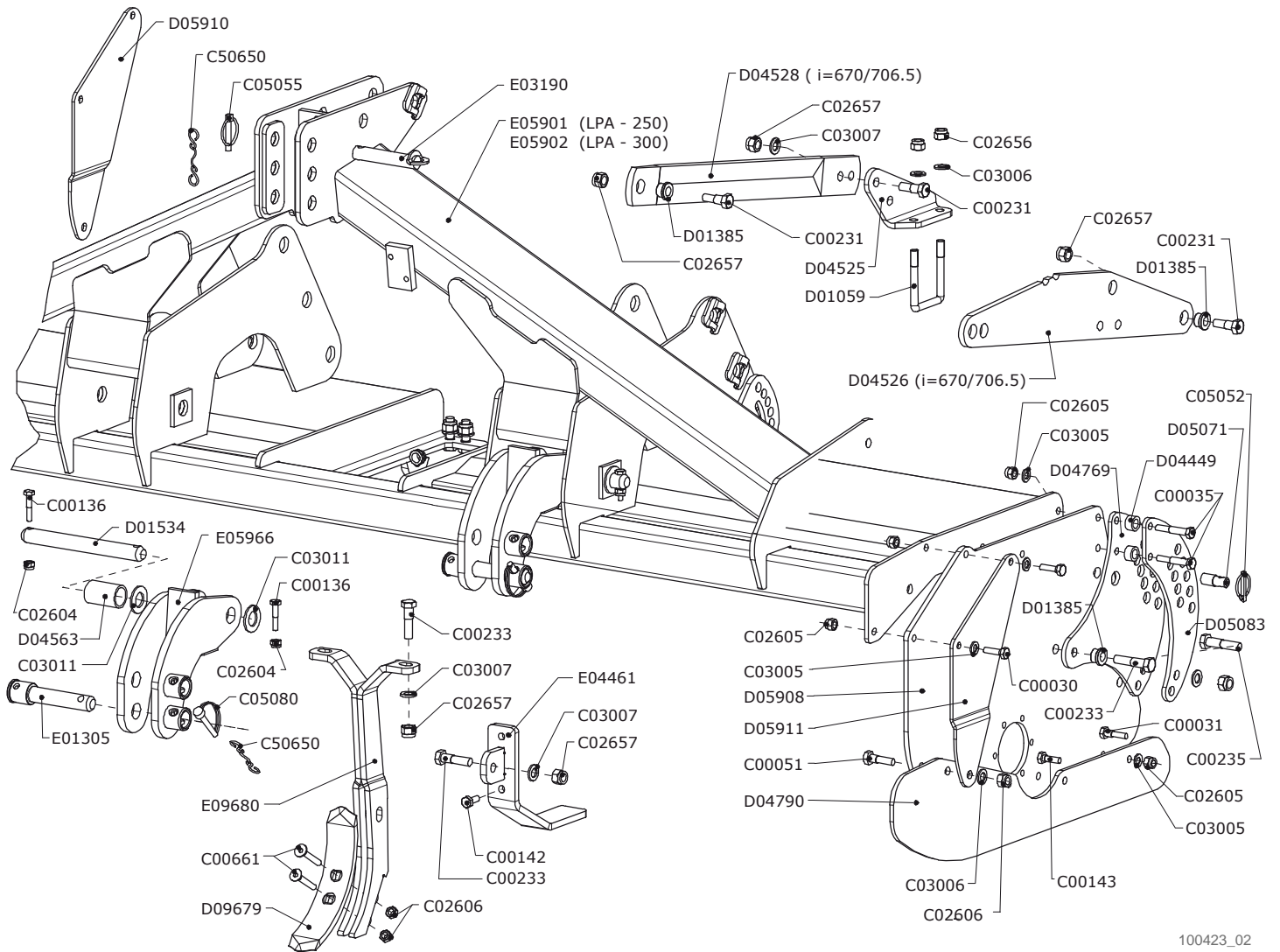

100423_02



Telaio
Frame
Chassis
Rahmen

Drawing Code: **100423_2**

Accessories:

N°	Code	Old.	Descrizione / Description	GB	FR	D	E
#	M80A00027	C00030	VITE TE 88 PG FP M12X40 ZINC UNI 5737	SCREW	VIS	SCHRAUBE	TORNILLO
#	M80A00028	C00031	VITE TE 88 PG FP M12X45 ZINC UNI 5737	SCREW	VIS	SCHRAUBE	TORNILLO
#	M80A00032	C00035	VITE TE 88 PG FP M12X70 ZINC UNI 5737	SCREW	VIS	SCHRAUBE	TORNILLO
#	M80A00044	C00051	VITE TE 88 PG FP M14X50 ZINC UNI 5737	SCREW	VIS	SCHRAUBE	TORNILLO
#	M80A00124	C00136	VITE TE 88 PG FT M10X50 ZINC UNI 5739	SCREW	VIS	SCHRAUBE	TORNILLO
#	M80A00129	C00142	VITE TE 88 PG FT M12X30 ZINC UNI 5739	SCREW	VIS	SCHRAUBE	TORNILLO
#	M80A00130	C00143	VITE TE 88 PG FT M12X35 ZINC UNI 5739	SCREW	VIS	SCHRAUBE	TORNILLO
#	M80A00180	C00231	VITE TE 88 PF FP M16X1,5X50 ZINC UNI 5738	SCREW	VIS	SCHRAUBE	TORNILLO
#	M80A00182	C00233	VITE TE 88 PF FP M16X1,5X60 ZINC UNI 573	SCREW	VIS	SCHRAUBE	TORNILLO
#	M80A00184	C00235	VITE TE 88 PF FP M16X1,5X70 ZINC UNI 573	SCREW	VIS	SCHRAUBE	TORNILLO
#	M80A00305	C00661	VITE TSPEI 10.9 PG M14X90 ZINC UNI 5933	SCREW	VIS	SCHRAUBE	TORNILLO
#	M85A00077	C02604	DADO AUTOBLOC ALTO 8 M10 H=11.5 UNI 7473	NUT	BOULONS	NUT	DADO
#	M85A00078	C02605	DADO AUTOBLOC ALTO 8 M12 H=14 UNI 7473	NUT	BOULONS	NUT	DADO
#	M85A00079	C02606	DADO AUTOBLOC ALTO 8 M14 H=16 UNI 7473	NUT	BOULONS	NUT	DADO
#	M85A00088	C02656	DADO AUTOBLOC ALTO 8 M14X1,5 H=16 UNI 7473	NUT	BOULONS	NUT	DADO
#	M85A00089	C02657	DADO AUTOBLOC ALTO 8 M16X1,5 H=18 UNI 7473	NUT	BOULONS	NUT	DADO
#	M90A00008	C03005	RONDELLA PIANA D.13 DIN125-A ZINC.	WASHER	RONDELLE	UNTERLEGSCHIEBE	ARANDELLA
#	M90A00009	C03006	RONDELLA PIANA D.15 DIN125-A ZINC.	WASHER	RONDELLE	UNTERLEGSCHIEBE	ARANDELLA
#	M90A00010	C03007	RONDELLA PIANA D.17 DIN125-A ZINC.	WASHER	RONDELLE	UNTERLEGSCHIEBE	ARANDELLA
#	M90A00014	C03011	RONDELLA PIANA D.28 DIN125-A ZINC.	WASHER	RONDELLE	UNTERLEGSCHIEBE	ARANDELLA
#	MB0A00093	C05052	SPINA A SCATTO D.8	SOCKET	GOUPILLE	STECKER	PASADOR
#	MB0A00096	C05055	SPINA A SCATTO D.10 CON TIRANTE IN GOMMA	SOCKET	GOUPILLE	STECKER	PASADOR
#	MB0A00101	C05080	SPINOTTO PER MOTOZAPPA D.10X60 UTILE	PIN	GOUPILLE	STIFT	PASADOR
#	M79A00002	C50650	GOMMINO CON ANELLI L.240 MM.	RUBBER	CAOUTCHOUC	BELAG	GOMAS
#	MD5A00002	D01059	CAVALLOTTO QUADRO M14 T70X70X105	PIN	CAVALLIER	STIFT	CAVALLOTTI
#	C15A00062	D01385	BUSSOLA D25/32 D.16,5 L.18,5 CARBON+ZINC	BUSHING	ENTRETOISE	BUCHSE	BRUJULA
#	M15A00017	D01534	PERNO D.28X224 UT.2 FORI D.11ZINC	PIN	PIVOT	STIFT	PIN
#	C00A00165	D04449	DIST. D.26,9 D.16,9 L.15	SPACER	ENTRETOISE	ABSTANDSTUECK	ESPACIADORES
#	C10A01461	D04525	STAFFA ATTACCO RULLO SERIE 2/3 10MM	BRACKET	SUPPORT	BUEGEL	SOPORTE
#	C05A04523	D04526	LAMA RULLO INF. LP i=670/706.5 12mm	METAL PLATE	LAME	METALL-PLATTE	CUCHILLA
#	C10A01462	D04528	LAMA RULLO SUPERIORE LP i=670/706.5	METAL PLATE	LAME	METALL-PLATTE	CUCHILLA
#	C00A00169	D04563	DIST. D.42,4 D.34,4 L.66	SPACER	ENTRETOISE	ABSTANDSTUECK	ESPACIADORES
#	C05A04598	D04769	PIASTRA INTERNA REG. RULLO FM/FP 8mm	PLATE	PLAQUE	PLATTE	PLACA
#	C05A04605	D04790	FIANCATINA CONT. FM/FP (RULLO) 8MM	SIDE	LONG	NEBEN	JUNTO
#	M15A00055	D05071	PERNO D.18/(20X26) UT. FORO D.9 ZINC***	PIN	PIVOT	STIFT	PIN
#	C05A04708	D05083	PIASTRA ESTERNA REG. RULLO FM/FP 8mm	PLATE	PLAQUE	PLATTE	PLACA
#	C05A05042	D05908	FIANCATA ESTERNA FPA/LPA/KPA 10mm	SIDE	LONG	NEBEN	JUNTO
#	C10A01675	D05910	RINFORZO DESTRO FIANCATA FPA/LPA/KPA	REINFORCEMENT	RENFORT	VERSTAERKUNG	REFUERZO
#	C10A01676	D05911	RINFORZO SINISTRO FIANCATA FPA/LPA/KPA	REINFORCEMENT	RENFORT	VERSTAERKUNG	REFUERZO
#	MK0A00149	D09679	VOMERE ROMPIRACCIA 40X16X270 2 FORI M14	PLOUGHSHARE	SOC	PFLUGSCHAR	REJA
#	M15A00169	E01305	PERNO D.28X106 UT.FORO D.12 SALD ZINC***	PIN	PIVOT	STIFT	PIN
#	M15A00172	E03190	PERNO ROND.25X109 UT.FORO D.12 ZINC***	PIN	PIVOT	STIFT	PIN
#	C20A00836	E04461	SUPPORTO ROMPIRACCIA FM	SUPPORT	SUPPORT	STUTZE	APOYO
#	C20A01081	E05901	TELAIO FPA/LPA/KPA-250	FRAME	CHASSIS	RAHMEN	MARCO
#	C20A01082	E05902	TELAIO FPA/LPA/KPA-300	FRAME	CHASSIS	RAHMEN	MARCO
#	C20A01097	E05966	ATTACCO TRATT. FPA/LPA/KPA	CONNECTION	ATTELAGE	ANSCHLUSS	ATAQUE
#	C20A01661	E09680	BRACCIO ROMPIRACCIA FM/FP D.15X45	ARM	BRAS	ARM	BRAZO

Copyright © 2009 Alpego s.p.a. ®

Tutti i diritti sono riservati. È vietata espressamente la ristampa o l'uso non autorizzato senza permesso scritto dalla Alpego s.p.a.
 Tous droits réservés. Toute réimpression ou utilisation non autorisée sans la permission écrite de la Alpego s.p.a. est formellement interdite.
 Alle Rechte vorbehalten. Nachdruck, Vervielfältigung und Verbreitung, auch auszugsweise, ist ohne schriftliche Genehmigung der Alpego s.p.a.
 All rights reserved. Any reprinting or unauthorized use without the written permission of Alpego s.p.a. is expressly prohibited.
 Todos los derechos reservados. Toda reproducción o uso no autorizado sin el consentimiento escrito de Alpego s.p.a. quedan expresamente prohibidos.

22/05/2014

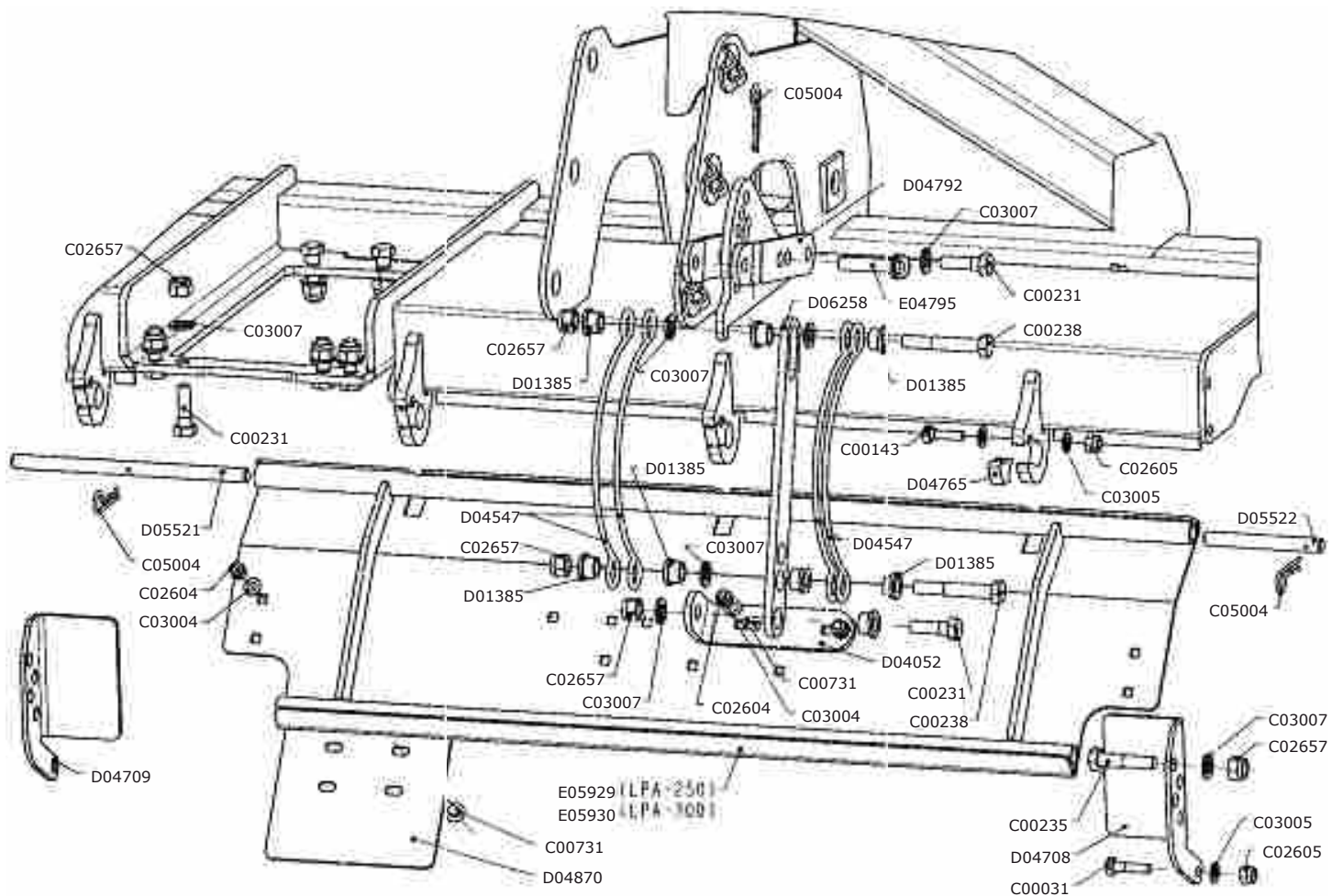

100424_00



Cofani
 Bonnets
 Capots
 Abdeckhauben

Drawing Code: **100424_0**

Accessories:

N°	Code	Old.	Descrizione / Description
#	M80A00028	C00031	VITE TE 88 PG FP M12X45 ZINC UNI 5737
#	M80A00130	C00143	VITE TE 88 PG FT M12X35 ZINC UNI 5739
#	M80A00180	C00231	VITE TE 88 PF FP M16X1,5X50 ZINC UNI 5738
#	M80A00184	C00235	VITE TE 88 PF FP M16X1,5X70 ZINC UNI 573
#	M80A00187	C00238	VITE TE 88 PF FP M16X1,5X100 ZINC UNI 57
#	MF0A00001	C00731	BULLONE TTQDE M10X30 UNI 5732 ZINC.BIANC
#	M85A00077	C02604	DADO AUTOBLOC ALTO 8 M10 H=11.5 UNI 7473
#	M85A00078	C02605	DADO AUTOBLOC ALTO 8 M12 H=14 UNI 7473
#	M85A00089	C02657	DADO AUTOBLOC ALTO 8 M16X1,5 H=18 UNI 7473
#	M90A00007	C03004	RONDELLA PIANA D.10,5 DIN125-A ZINC.
#	M90A00008	C03005	RONDELLA PIANA D.13 DIN125-A ZINC.
#	M90A00010	C03007	RONDELLA PIANA D.17 DIN125-A ZINC.
#	MB0A00087	C05004	SPINA A MOLLA D.4
#	C15A00062	D01385	BUSSOLA D25/32 D.16,5 L.18,5 CARBON+ZINC
#	C10A01397	D04052	STAFFA INF. FISSAGGIO PREMICOFANO FM FP FH
#	MG0A00002	D04547	BALESTRA COFANO D.6,4
#	C10A01494	D04708	PIASTRINA DES. CHIUSURA BARRA AFF. LP
#	C10A01495	D04709	PIASTRINA SIN. CHIUSURA BARRA AFF. LP
#	C05A04594	D04765	FERMO GANCIO COFANI FM/FP 15MM
#	C10A01515	D04792	BRACCIO REGISTRO COFANI FM/FP
#	C05A04639	D04870	CHIUSURA CENTRALE COFANI LH/KH/LP/KP SP6
#	C15A00390	D05521	BACCHETTA CENTR. 17X300 COFANI A GANCIO
#	C15A00391	D05522	BACCHETTA LATER. 17X150 COFANI A GANCIO
#	C05A05187	D06258	FINECORSO BALESTRA COFANI FPA-LPA 10MM
#	M15A00176	E04795	PERNO ROND D.16X66,7 UT.FOROD.4,5ZINC***
#	C20A01087	E05929	COFANO RINFORZATO FPA-250
#	C20A01088	E05930	COFANO RINFORZATO FPA-300

GB	FR	D	E
SCREW	VIS	SCHRAUBE	TORNILLO
SCREW	VIS	SCHRAUBE	TORNILLO
SCREW	VIS	SCHRAUBE	TORNILLO
SCREW	VIS	SCHRAUBE	TORNILLO
SCREW	VIS	SCHRAUBE	TORNILLO
BOLT	BOULON	FLANSCH	BRIDA
NUT	BOULONS	NUT	DADO
NUT	BOULONS	NUT	DADO
NUT	BOULONS	NUT	DADO
WASHER	RONDELLE	UNTERLEGSCHLEIBE	ARANDELLA
WASHER	RONDELLE	UNTERLEGSCHLEIBE	ARANDELLA
WASHER	RONDELLE	UNTERLEGSCHLEIBE	ARANDELLA
SOCKET	GOUPILLE	STECKER	PASADOR
BUSHING	ENTRETOISE	BUCHSE	BRUJULA
BRACKET	SUPPORT	BUEGEL	SOPORTE
CROSSBOARD	RESSORT	BLATTFEDER	BALLESTA
METAL STRAP	METAL DEPLOYE	BANDEISEN	PLATILLO
METAL STRAP	METAL DEPLOYE	BANDEISEN	PLATILLO
MECH. STOP	FERMETURE	MECH. SPERRUNG	PARADO
ARM	BRAS	ARM	BRAZO
GATE	FERMETURE	VERSCHLUSS	CIERRE
ROD	TUBE	STIFT	BAQUETAS
ROD	TUBE	STIFT	BAQUETAS
STOP	FIN DE COURSE	ENDANSCHLAG	LÍMITE
PIN	PIVOT	STIFT	PIN
BONNET	CAPOT	MOTORHAUBE	CAPÓ
BONNET	CAPOT	MOTORHAUBE	CAPÓ

Barra affinamento BA3 frese

Rear bar BA3

Barra arriere BA3

Hintere stange BA3

Drawing Code:

100312_0

Accessories:

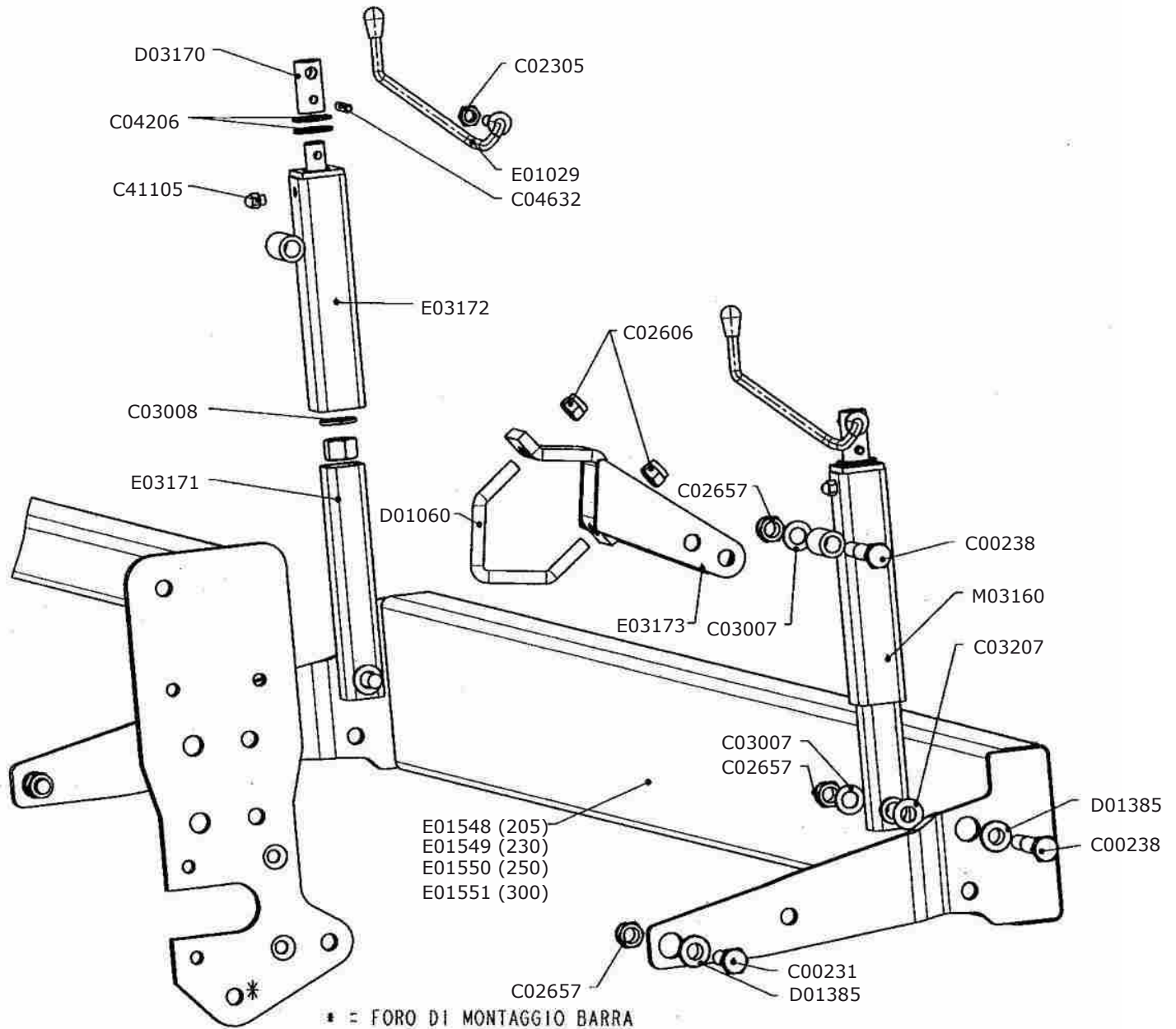

100312_00



Barra affinamento BA3 frese

Rear bar BA3

Barra arriere BA3

Hintere stange BA3

Drawing Code:

100312_0

Accessories:

N°	Code	Old.	Descrizione / Description
#	M80A00180	C00231	VITE TE 88 PF FP M16X1,5X50 ZINC UNI 5738
#	M80A00187	C00238	VITE TE 88 PF FP M16X1,5X100 ZINC UNI 57
#	M85A00050	C02305	DADO METALBLOC M12 X 1.75
#	M85A00079	C02606	DADO AUTOBLOC ALTO 8 M14 H=16 UNI 7473
#	M85A00089	C02657	DADO AUTOBLOC ALTO 8 M16X1,5 H=18 UNI 7473
#	M90A00010	C03007	RONDELLA PIANA D.17 DIN125-A ZINC.
#	M90A00011	C03008	RONDELLA PIANA D.21 DIN125-A ZINC.
#	M90A00053	C03207	DISCO ELAST. D.16,3X31,5X1,75 ZINC+DEIDR DIN 2093
#	MA5A00005	C04206	SPESSORE 28x40x2 ZINC.+DEIDR. HRC 44
#	MB0A00065	C04632	SPINA SPIROL D.8X40
#	MJ5A00005	C41105	INGRASSATORE M10X1 DIRITTO
#	MD5A00003	D01060	CAVALLOTTO DIAGONALE M14 70X70
#	C15A00062	D01385	BUSSOLA D25/32 D.16,5 L.18,5 CARBON+ZINC
#	C15A00233	D03170	DIST. D.26,9 D.20 L.53+FORO D.8+FORO D.12
#	C20A00074	E01029	MANOVELLA M12 PER BARRE
#	C20A00225	E01548	BARRA AFFINAMENTO BA3- 205
#	C20A00227	E01549	BARRA AFFINAMENTO BA3-230
#	C20A00228	E01550	BARRA AFFINAMENTO BA3-250
#	C20A00230	E01551	BARRA AFFINAMENTO BA3-300
#	C20A00561	E03171	TUBO INTERNO MANOVELLA BA2-BA3 M20
#	C20A00562	E03172	TUBO EST. MANOVELLA BA2-BA3
#	C20A00563	E03173	STAFFA PORTA MANOVELLA BA2-BA3
#	M79A00017	M03160	MANOVELLA COMPLET. BA2-BA3 CORSA 200 ZINCATA BIANCA

GB	FR	D	E
SCREW	VIS	SCHRAUBE	TORNILLO
SCREW	VIS	SCHRAUBE	TORNILLO
NUT	BOULONS	NUT	DADO
NUT	BOULONS	NUT	DADO
NUT	BOULONS	NUT	DADO
WASHER	RONDELLE	UNTERLEGSCHLEIBE	ARANDELLA
WASHER	RONDELLE	UNTERLEGSCHLEIBE	ARANDELLA
DISC	DISQUE	SCHLEIBE	DISCO
THICKNESS	CALES	DICKE	ESPESOR
SOCKET	GOUPILLE	STECKER	PASADOR
GREASE NIPPLE	GRAISSOR	FETTBUECHSE	ENGRASADOR
PIN	CAVALLIER	STIFT	CAVALLOTTI
BUSHING	ENTRETOISE	BUCHSE	BRUJULA
SPACER	ENTRETOISE	ABSTANDSTUECK	ESPACIADORES
CRANK	MANIVELLE	SPINDEL	MANIVELA
BAR	BARRE	STAB	BARRA
BAR	BARRE	STAB	BARRA
BAR	BARRE	STAB	BARRA
BAR	BARRE	STAB	BARRA
TUBE	TUBE	ROHR	TUBO
TUBE	TUBE	ROHR	TUBO
BRACKET	SUPPORT	BUEGEL	SOPORTE
CRANK	MANIVELLE	SPINDEL	MANIVELA

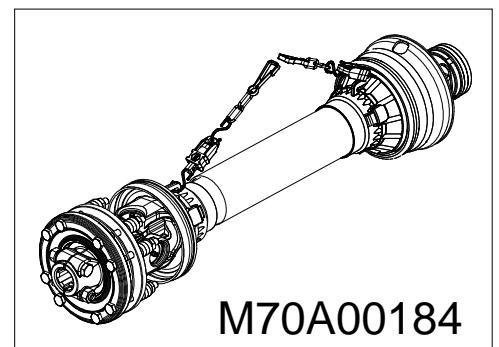
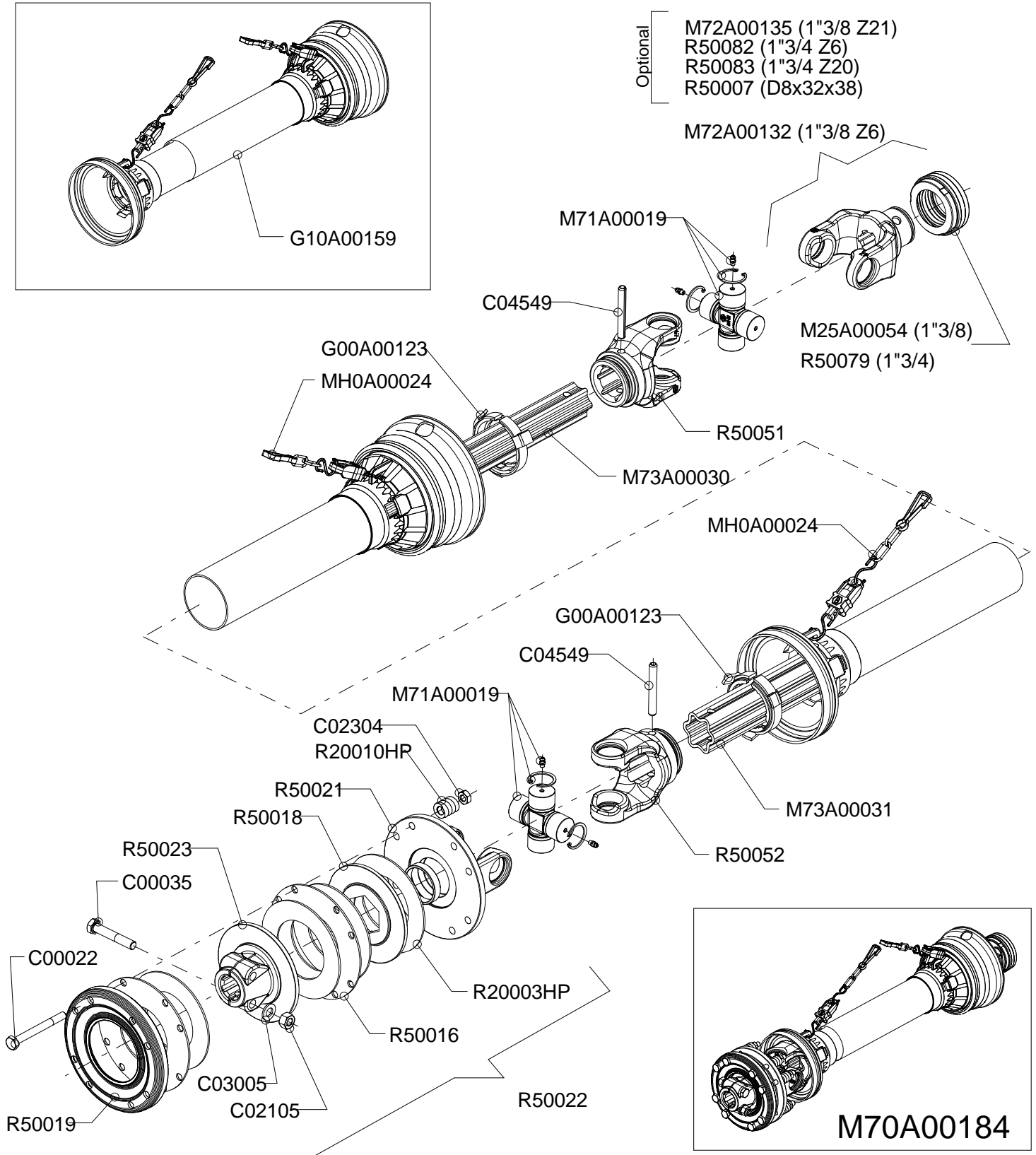
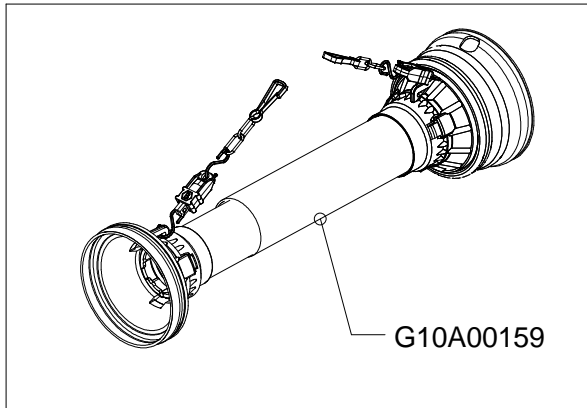



Cardano

Pto shaft

Arbre de transmission

Gelenkwelle

Drawing Code: **K00A01105_0**

Accessories: M70A00184

N°	Code	Old.	Descrizione / Description
#	M80A00019	C00022	VITE TE 88 PG FP M10X100 ZINC UNI 5737
#	M80A00032	C00035	VITE TE 88 PG FP M12X70 ZINC UNI 5737
#	M85A00028	C02105	DADO NORMALE 8 PG M12 UNI 5588
#	M85A00049	C02304	DADO METALBLOC M10
#	M90A00008	C03005	RONDELLA PIANA D.13 DIN125-A ZINC.
#	MB0A00037	C04549	SPINA ELASTICA D.10X90
#	G00A00123		GHIERA TIPO EVO DI 72.64 (V08)
#	G10A00159		PROT. COMPL. L=1210 CARDANI BENZI (V08)
#	M25A00054		"COLLARE ATTACCO RAPIDO ACCIAIO 1" 3/8"
#	M70A00184		"CARDANO V08-1019 F4(1600NM) 1"3/4 Z6-1"3/8 Z6"
#	M71A00019		CROCIERA V08 35X106.5
#	M72A00132		"FORCELLA T67 1"3/8 Z=6 COLLARE RAPIDO ACCIAIO (V08)"
#	M72A00135		"FORCELLA T67 1"3/8 Z=21 COLLARE RAPIDO ACCIAIO (V08)"
#	M73A00030	R50055	TUBO STELLARE 51x37x515 BONIFICATO
#	M73A00031	R50056	TUBO STELLARE 61x47x4,5x515 CEMENTATO
#	MH0A00024		CATENA SGANCIO PROGRAMMATO COMPLETA
#	G15A00005	R20003HP	DISCO ATTRITO FD4 160X97X3.5 HIGH PERFORM.
#	MF5A00055	R20010HP	MOLLA PER FD4 FILO D.7 L= 33MM HP (M04666)
#	M72A00038	R50007	FORCELLA 8 D8X32X38 (RUSSIA)
#	C15A00845	R50016	DISCO INTERNO F4 200x3
#	C15A00846	R50018	DISCO DI TRASCINAMENTO F4
#	C15A00847	R50019	DISCO DI PRESSIONE F4-8
#	M72A00043	R50021	FORCELLA A FLANGIA F4-8
#	M75A00058	R50022	"FRIZIONE COMPL.FD4-8 1"3/4 Z=6 2200NM"
#	M75A00059	R50023	"MOZZO FRIZIONE F4-8 1"3/4 Z=6"
#	M72A00048	R50051	FORCELLA TUBO S4V ANELLO 72X8.5 (R08)
#	M72A00049	R50052	FORCELLA TUBO S5H ANELLO 72X8.5 (R08)
#	M25A00022	R50079	"COLLARE ATTACCO RAPIDO HL400 1" 3/4"
#	M72A00053	R50082	"FORCELLA 1"3/4 Z=6 COLLARE RAPIDO ACCIAIO"
#	M72A00054	R50083	"FORCELLA 1"3/4 Z=20 COLLARE RAPIDO ACCIAIO"

GB	FR	D	E
SCREW	VIS	SCHRAUBE	TORNILLO
SCREW	VIS	SCHRAUBE	TORNILLO
NUT	BOULONS	NUT	DADO
NUT	BOULONS	NUT	DADO
WASHER	RONDELLE	UNTERLEGSCHIEBE	ARANDELLA
SOCKET	GOUPILLE	STECKER	PASADOR
METAL RING	RONDELLE	METALL-RING	RUEDA
PROTECTION	PROTECTION	SCHUTZ	PROTECCIÓN
METAL RING	COLLARE	METALLRING	COLLAR
UNIVERSAL JOINT	CARDAN	GELLENKWELLE	CARDAN
CRUISE	CROISIÈRE	CRUISE	CRUISE
FORK	MACHOIRE	GABEL	HORQUILLA
FORK	MACHOIRE	GABEL	HORQUILLA
TUBE	TUBE	ROHR	TUBO
TUBE	TUBE	ROHR	TUBO
CHAIN	CHAINE	KETTE	CADENA
DISC	DISQUE	SCHEIBE	DISCO
SPRING	RESSORT	FEDER	MUELLE
FORK	MACHOIRE	GABEL	HORQUILLA
DISC	DISQUE	SCHEIBE	DISCO
DISC	DISQUE	SCHEIBE	DISCO
DISC	DISQUE	SCHEIBE	DISCO
FORK	MACHOIRE	GABEL	HORQUILLA
CLUTCH	EMBAYAGE	KUPPLUNG	EMBRAGUE
HUB	ESSIEU	NABE	MAZO
FORK	MACHOIRE	GABEL	HORQUILLA
FORK	MACHOIRE	GABEL	HORQUILLA
METAL RING	COLLARE	METALLRING	COLLAR
FORK	MACHOIRE	GABEL	HORQUILLA
FORK	MACHOIRE	GABEL	HORQUILLA

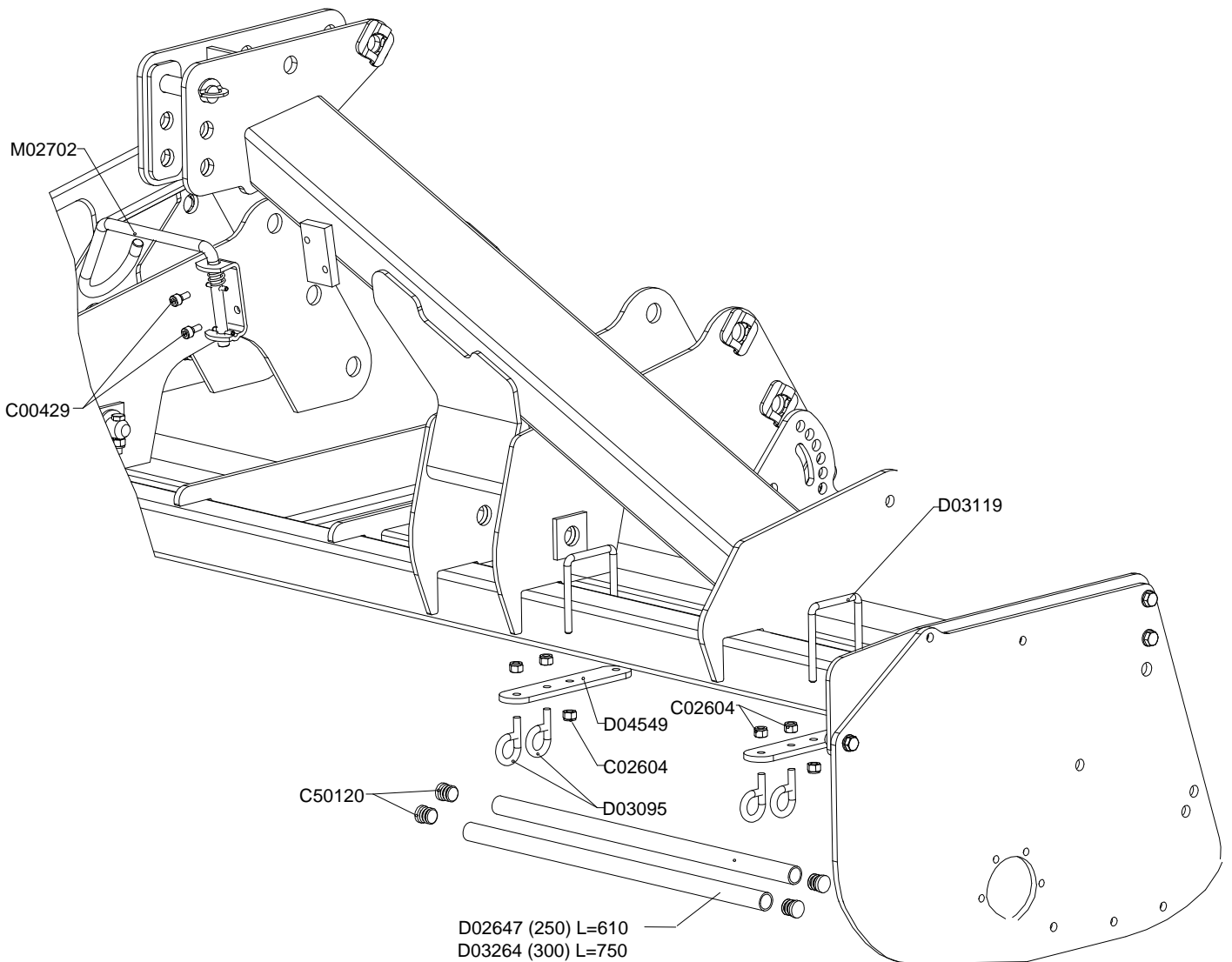

100407_01



Kit C.E.

Kit C.E.

Kit C.E.

Kit C.E.

Drawing Code: **100407_1**

Accessories:

N°	Code	Old.	Descrizione / Description
#	M80A00242	C00429	VITE TCEI PG M10X20 ZINC UNI 5931
#	M85A00077	C02604	DADO AUTOBLOC ALTO 8 M10 H=11.5 UNI 7473
#	G10A00007	C50120	TAPPO PLASTICA TUBO D.25
#	C00A00064	D02647	TUBO PROTEZIONE L=610
#	MH5A00041	D03095	GANCIO M10 PER TUBO D. 26,9
#	MD5A00011	D03119	CAVALLOTTO QUADRO M10 80x80
#	C00A00110	D03264	TUBO PROTEZIONE L=750
#	C05A04526	D04549	STAFFA PROT. ANTER. FM-FP 8MM
#	M79A00013	M02702	GANCIO SUPP. CARDANO COMPL.***

GB	FR	D	E
SCREW	VIS	SCHRAUBE	TORNILLO
NUT	BOULONS	NUT	DADO
PLUG	BOUCHON	STOEPSSEL	ENCHUFE
TUBE	TUBE	ROHR	TUBO
HOOK	ATTACHE	HAKEN	ENGANCHE
PIN	CAVALLIER	STIFT	CAVALLOTTI
TUBE	TUBE	ROHR	TUBO
BRACKET	SUPPORT	BUEGEL	SOPORTE
HOOK	ATTACHE	HAKEN	ENGANCHE

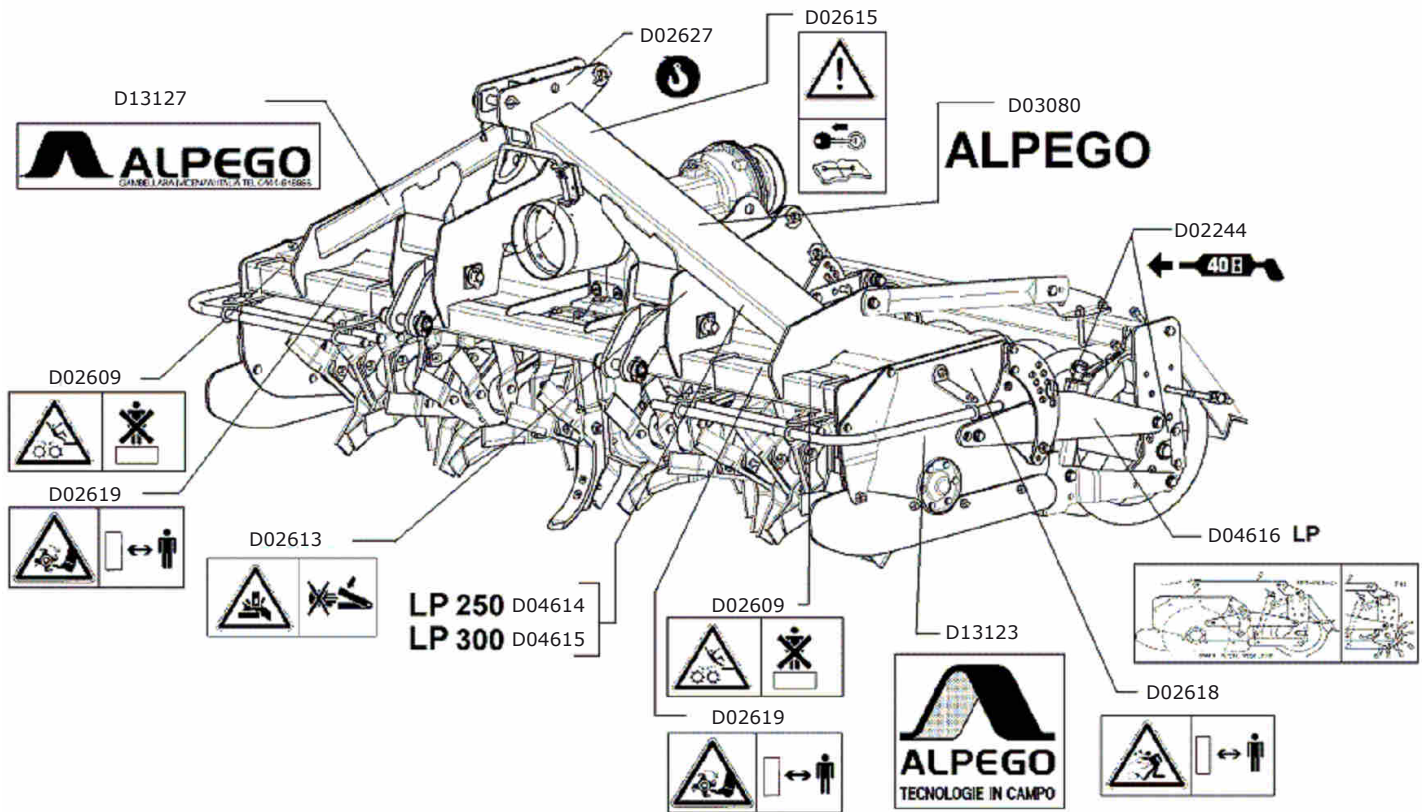



Kit adesivi di sicurezza LP

Kit adhesive of emergency LP

Kit adhesifs de sa»rete LP

Installationssatzkleber der Dringlichkeit LP

Drawing Code:

100353_0

Accessories:

N°	Code	Old.	Descrizione / Description
#	Q15A00067	D02244	ADESIVO INGRASSAGGIO FREQ.40H 55X25
#	Q15A00076	D02609	ADESIVO VIETATO SALIRE 110X55
#	Q15A00080	D02613	ADESIVO PERICOLO CESOIAM. 110X55
#	Q15A00082	D02615	ADESIVO TOGLIERE ENERGIA 110X55
#	Q15A00085	D02618	ADESIVO PROIEZIONE SASSI 55X110
#	Q15A00086	D02619	ADESIVO STARE LONTANI FRESA 55X110
#	Q15A00094	D02627	ADESIVO GANCIO DI SOLLEV. D.30
#	Q15A00106	D03080	ADESIVO ALPEGO INTAGLIATO 105X625
#	Q15A00163	D04614	ADESIVO: LP-250 (ROSSO H=45)
#	Q15A00164	D04615	ADESIVO: LP-300 (ROSSO H=45)
#	Q15A00165	D04616	ADESIVO MONTAGGIO RULLO LP
#	Q15A00393	D13123	ADESIVO ALPEGO LA MIGL. TECN. IN CAMPO 120X86.5
#	Q15A00397	D13127	ADESIVO ALPEGO 250X50

GB	FR	D	E
STICKER	ADHESIF	AUFKLEBER	ADHESIVOS
STICKER	ADHESIF	AUFKLEBER	ADHESIVOS
STICKER	ADHESIF	AUFKLEBER	ADHESIVOS
STICKER	ADHESIF	AUFKLEBER	ADHESIVOS
STICKER	ADHESIF	AUFKLEBER	ADHESIVOS
STICKER	ADHESIF	AUFKLEBER	ADHESIVOS
STICKER	ADHESIF	AUFKLEBER	ADHESIVOS
STICKER	ADHESIF	AUFKLEBER	ADHESIVOS
STICKER	ADHESIF	AUFKLEBER	ADHESIVOS
STICKER	ADHESIF	AUFKLEBER	ADHESIVOS
STICKER	ADHESIF	AUFKLEBER	ADHESIVOS
STICKER	ADHESIF	AUFKLEBER	ADHESIVOS
STICKER	ADHESIF	AUFKLEBER	ADHESIVOS
STICKER	ADHESIF	AUFKLEBER	ADHESIVOS



Kit adesivi di sicurezza LP

Kit adhesive of emergency LP

Kit adhesifs de sa»rete LP

Installationssatzkleber der Dringlichkeit LP

Drawing Code:

100354_0

Accessories:

N°	Code	Old.	Descrizione / Description	GB	FR	D	E
#	Q15A00005	D00983	ADESIVO ATTENZIONE SERRAGGIO 135X110	STICKER	ADHESIF	AUFKLEBER	ADHESIVOS
#	Q15A00009	D01203	ADESIVO 540 GIRI TONDO D.58 GIALLO	STICKER	ADHESIF	AUFKLEBER	ADHESIVOS
#	Q15A00067	D02244	ADESIVO INGRASSAGGIO FREQ.40H 55X25	STICKER	ADHESIF	AUFKLEBER	ADHESIVOS
#	Q15A00075	D02608	ADESIVO PROTEZIONE ALBERI 110X55	STICKER	ADHESIF	AUFKLEBER	ADHESIVOS
#	Q15A00076	D02609	ADESIVO VIETATO SALIRE 110X55	STICKER	ADHESIF	AUFKLEBER	ADHESIVOS
#	Q15A00079	D02612	ADESIVO LIBRETTO ISTR. 168X88	STICKER	ADHESIF	AUFKLEBER	ADHESIVOS
#	Q15A00080	D02613	ADESIVO PERICOLO CESOIAM. 110X55	STICKER	ADHESIF	AUFKLEBER	ADHESIVOS
#	Q15A00085	D02618	ADESIVO PROIEZIONE SASSI 55X110	STICKER	ADHESIF	AUFKLEBER	ADHESIVOS
#	Q15A00093	D02626	ADESIVO NON APRIRE COFANI 55x110	STICKER	ADHESIF	AUFKLEBER	ADHESIVOS
#	Q15A00106	D03080	ADESIVO ALPEGO INTAGLIATO 105X625	STICKER	ADHESIF	AUFKLEBER	ADHESIVOS
#	Q15A00160	D04560	ADESIVO N GIRI T+C 130 FP/LP	STICKER	ADHESIF	AUFKLEBER	ADHESIVOS
#	Q15A00163	D04614	ADESIVO: LP-250 (ROSSO H=45)	STICKER	ADHESIF	AUFKLEBER	ADHESIVOS
#	Q15A00164	D04615	ADESIVO: LP-300 (ROSSO H=45)	STICKER	ADHESIF	AUFKLEBER	ADHESIVOS
#	Q15A00185	D05399	ADESIVO OLIO EP-C 320	STICKER	ADHESIF	AUFKLEBER	ADHESIVOS
#	Q15A00393	D13123	ADESIVO ALPEGO LA MIGL. TECN. IN CAMPO 120X86.5	STICKER	ADHESIF	AUFKLEBER	ADHESIVOS
#	Q15A00397	D13127	ADESIVO ALPEGO 250X50	STICKER	ADHESIF	AUFKLEBER	ADHESIVOS

Rullo spiral SP3

Spiral roller SP3

Rouleau spiral SP3

Spiral walze SP3

Drawing Code: **100016_2**

Accessories:

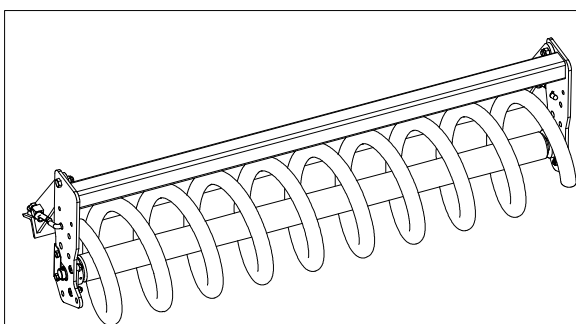
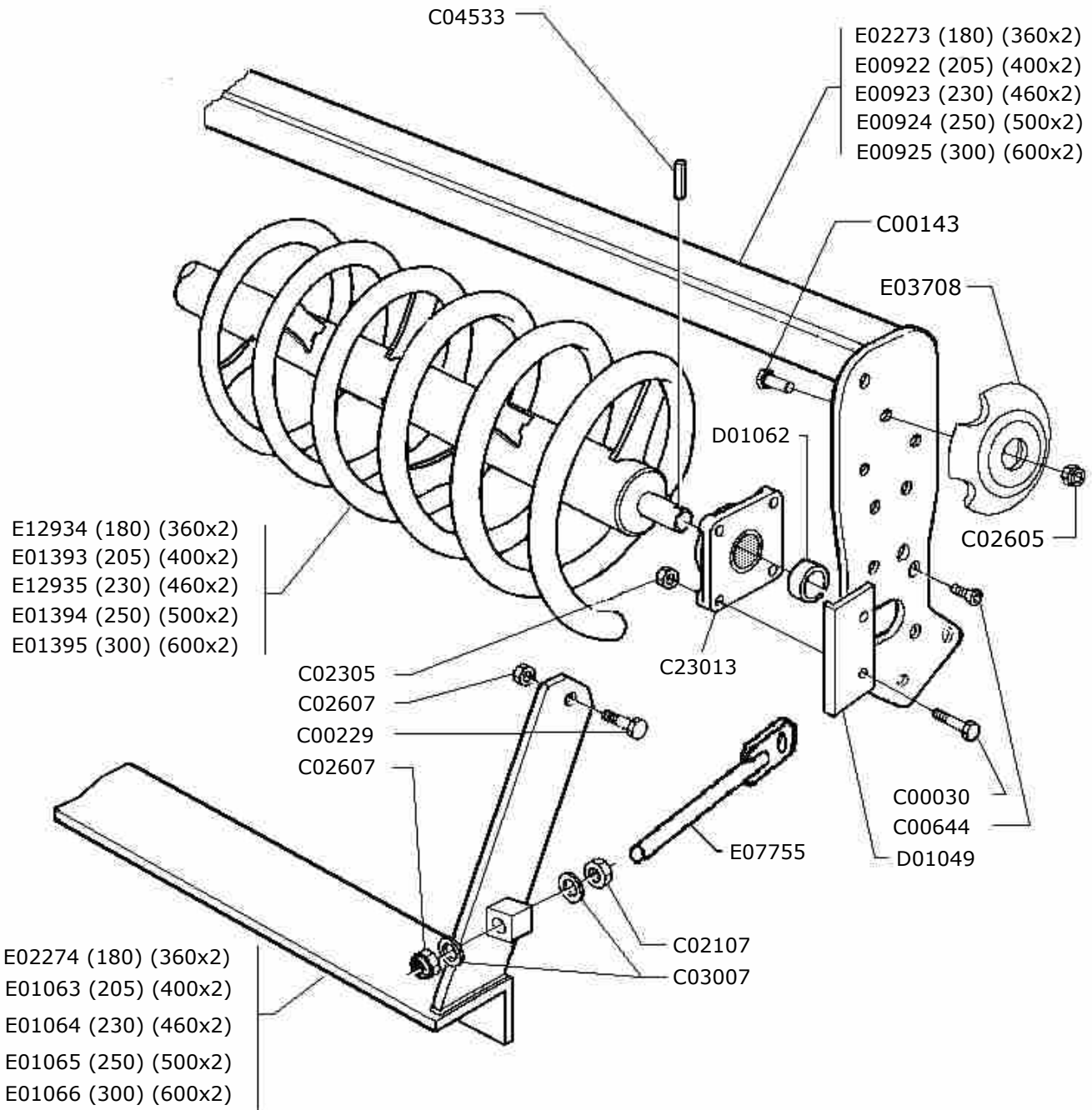

S02017 (SP3-180)
S02014 (SP3-205)
S02019 (SP3-230)
S02015 (SP3-250)
S02016 (SP3-300)

100016_02



Rullo spiral SP3
Spiral roller SP3
Rouleau spiral SP3
Spiral walze SP3

Drawing Code:

100016_2

Accessories:

N°	Code	Old.	Descrizione / Description	GB	FR	D	E
#	M80A00027	C00030	VITE TE 88 PG FP M12X40 ZINC UNI 5737	SCREW	VIS	SCHRAUBE	TORNILLO
#	M80A00130	C00143	VITE TE 88 PG FT M12X35 ZINC UNI 5739	SCREW	VIS	SCHRAUBE	TORNILLO
#	M80A00179	C00229	VITE TE 10.9 M16X1,5X45 ZINC F25	SCREW	VIS	SCHRAUBE	TORNILLO
#	M80A00292	C00644	VITE TSPEI 10.9 PG M12X40 ZINC UNI 5933	SCREW	VIS	SCHRAUBE	TORNILLO
#	M85A00030	C02107	DADO NORMALE 8 PG M16 UNI 5588 ZINC	NUT	BOULONS	NUT	DADO
#	M85A00050	C02305	DADO METALBLOC M12 X 1.75	NUT	BOULONS	NUT	DADO
#	M85A00078	C02605	DADO AUTOBLOC ALTO 8 M12 H=14 UNI 7473	NUT	BOULONS	NUT	DADO
#	M85A00080	C02607	DADO AUTOBLOC ALTO 8 M16 H=18 UNI 7473	NUT	BOULONS	NUT	DADO
#	M90A00010	C03007	RONDELLA PIANA D.17 DIN125-A ZINC.	WASHER	RONDELLE	UNTERLEGSCHIEBE	ARANDELLA
#	MB0A00022	C04533	SPINA ELASTICA D.8X45	SOCKET	GOUPILLE	STECKER	PASADOR
#	M30A00004	C23013	SUPPORTO UCF 207	SUPPORT	SUPPORT	STUTZE	APOYO
#	C05A03920	D01049	PIASTRINA POST. PER UCF 207	METAL STRAP	METAL DEPLOYE	BANDEISEN	PLATILLO
#	C00A00006	D01062	DIST. D.42,4 D.35,5 L.14	SPACER	ENTRETOISE	ABSTANDSTUECK	ESPACIADORES
#	C20A00052	E00922	TELAIO RULLO 205	FRAME	CHASSIS	RAHMEN	MARCO
#	C20A00053	E00923	TELAIO RULLO 230	FRAME	CHASSIS	RAHMEN	MARCO
#	C20A00054	E00924	TELAIO RULLO 250	FRAME	CHASSIS	RAHMEN	MARCO
#	C20A00055	E00925	TELAIO RULLO 300	FRAME	CHASSIS	RAHMEN	MARCO
#	C20A00087	E01063	TELAIO RASCHIATORE 205	FRAME	CHASSIS	RAHMEN	MARCO
#	C20A00088	E01064	TELAIO RASCHIATORE 230	FRAME	CHASSIS	RAHMEN	MARCO
#	C20A00089	E01065	TELAIO RASCHIATORE 250	FRAME	CHASSIS	RAHMEN	MARCO
#	C20A00090	E01066	TELAIO RASCHIATORE 300	FRAME	CHASSIS	RAHMEN	MARCO
#	C20A00172	E01393	RULLO SPIRAL SP3 205	ROLLER	ROULEAU	WALZE	RODILLO
#	C20A00173	E01394	RULLO SPIRAL SP3 250	ROLLER	ROULEAU	WALZE	RODILLO
#	C20A00174	E01395	RULLO SPIRAL SP3 300	ROLLER	ROULEAU	WALZE	RODILLO
#	C20A00374	E02273	TELAIO RULLO 180	FRAME	CHASSIS	RAHMEN	MARCO
#	C20A00375	E02274	TELAIO RASCHIATORE 180	FRAME	CHASSIS	RAHMEN	MARCO
#	C20A00698	E03708	TAMPONE CENTRALE RULLI DOPPI D.145X30	BUFFER	PRESSE	STOPFEN	TAMPON
#	C20A01375	E07755	TIRANTE RASCHIATORE M16 CON PIASTRINA	TIE ROD	TIRANT	ZUGSTANGE	TIRANTE
#	C20A02042	E12934	RULLO SPIRAL SP3 180	ROLLER	ROULEAU	WALZE	RODILLO
#	C20A02043	E12935	RULLO SPIRAL SP3 230	ROLLER	ROULEAU	WALZE	RODILLO
#	S00A00013	S02014	RULLO SPIRAL SP3 205 D.450 COMPLETO	ROLLER	ROULEAU	WALZE	RODILLO
#	S00A00014	S02015	RULLO SPIRAL SP3 250 D.450 COMPLETO	ROLLER	ROULEAU	WALZE	RODILLO
#	S00A00015	S02016	RULLO SPIRAL SP3 300 D.450 COMPLETO	ROLLER	ROULEAU	WALZE	RODILLO
#	S00A00017	S02017	RULLO SPIRAL SP3-180 D.450 COMPLETO	ROLLER	ROULEAU	WALZE	RODILLO
#	S00A00019	S02019	RULLO SPIRAL SP3 230 D.450 COMPLETO	ROLLER	ROULEAU	WALZE	RODILLO

Rullo packer PK3

Packer roller PK3

Rouleau packer PK3

Packer walze PK3

Drawing Code: **100017_1**

Accessories:

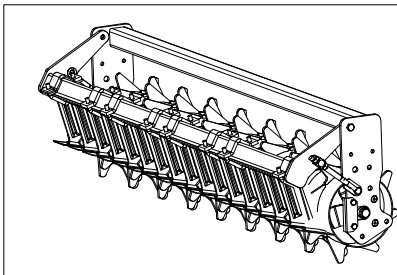
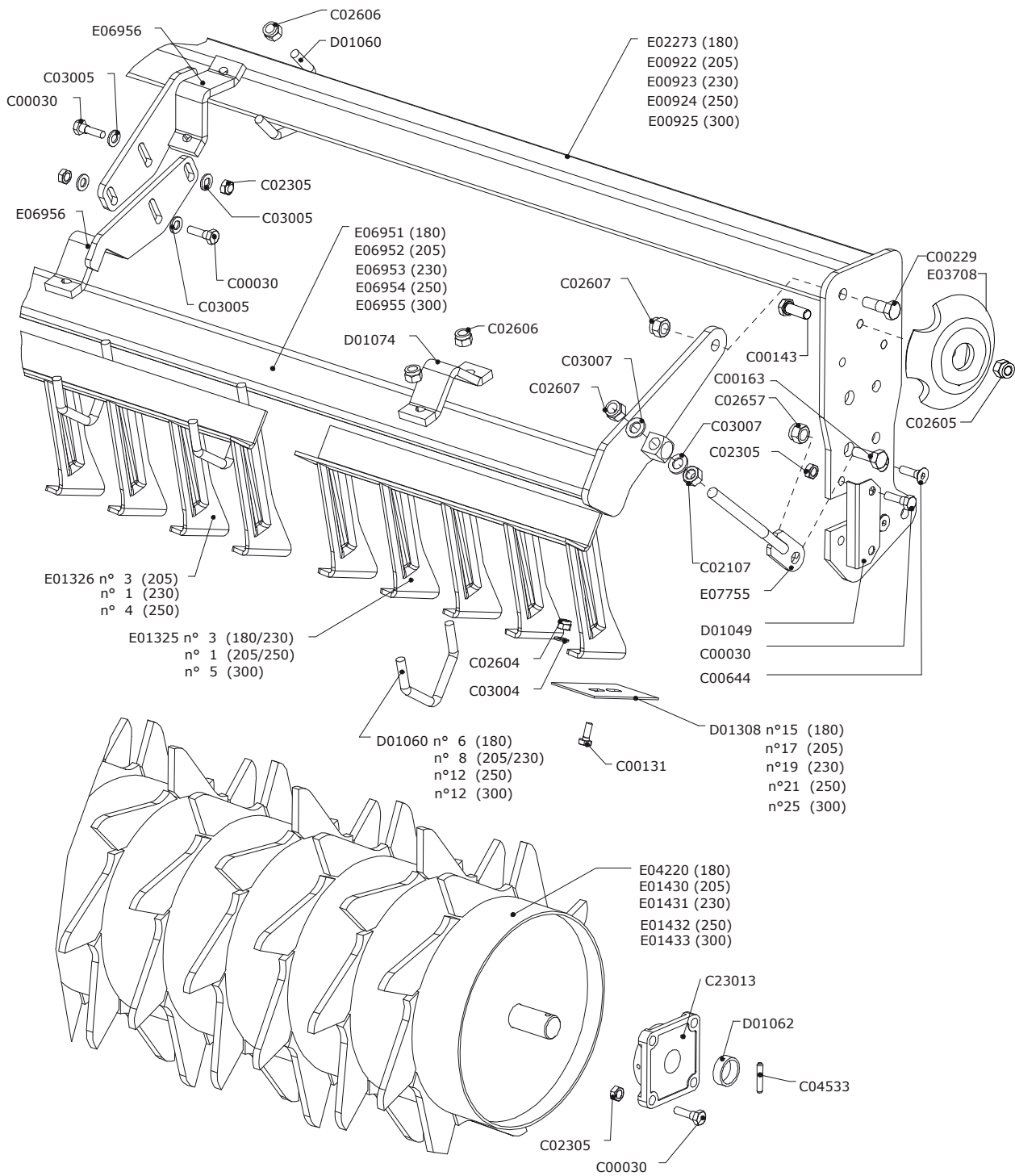

- S03008 (PK3-180)
- S03005 (PK3-205)
- S03010 (PK3-230)
- S03006 (PK3-250)
- S03007 (PK3-300)

100017_01



Rullo packer PK3
Packer roller PK3
Rouleau packer PK3
Packer walze PK3

Drawing Code: **100017_1**

Accessories:

N°	Code	Old.	Descrizione / Description	GB	FR	D	E
#	M80A00027	C00030	VITE TE 88 PG FP M12X40 ZINC UNI 5737	SCREW	VIS	SCHRAUBE	TORNILLO
#	M80A00118	C00131	VITE TE 88 PG FT M10X25 ZINC UNI 5739	SCREW	VIS	SCHRAUBE	TORNILLO
#	M80A00130	C00143	VITE TE 88 PG FT M12X35 ZINC UNI 5739	SCREW	VIS	SCHRAUBE	TORNILLO
#	M80A00149	C00163	VITE TE 88 PG FT M16X40 ZINC UNI 5739	SCREW	VIS	SCHRAUBE	TORNILLO
#	M80A00179	C00229	VITE TE 10.9 M16X1,5X45 ZINC F25	SCREW	VIS	SCHRAUBE	TORNILLO
#	M80A00292	C00644	VITE TSPEI 10.9 PG M12X40 ZINC UNI 5933	SCREW	VIS	SCHRAUBE	TORNILLO
#	M85A00030	C02107	DADO NORMALE 8 PG M16 UNI 5588 ZINC	NUT	BOULONS	NUT	DADO
#	M85A00050	C02305	DADO METALBLOC M12 X 1.75	NUT	BOULONS	NUT	DADO
#	M85A00077	C02604	DADO AUTOBLOC ALTO 8 M10 H=11.5 UNI 7473	NUT	BOULONS	NUT	DADO
#	M85A00078	C02605	DADO AUTOBLOC ALTO 8 M12 H=14 UNI 7473	NUT	BOULONS	NUT	DADO
#	M85A00079	C02606	DADO AUTOBLOC ALTO 8 M14 H=16 UNI 7473	NUT	BOULONS	NUT	DADO
#	M85A00080	C02607	DADO AUTOBLOC ALTO 8 M16 H=18 UNI 7473	NUT	BOULONS	NUT	DADO
#	M85A00089	C02657	DADO AUTOBLOC ALTO 8 M16X1,5 H=18 UNI 7473	NUT	BOULONS	NUT	DADO
#	M90A00007	C03004	RONDELLA PIANA D.10,5 DIN125-A ZINC.	WASHER	RONDELLE	UNTERLEGSCHLEIBE	ARANDELLA
#	M90A00008	C03005	RONDELLA PIANA D.13 DIN125-A ZINC.	WASHER	RONDELLE	UNTERLEGSCHLEIBE	ARANDELLA
#	M90A00010	C03007	RONDELLA PIANA D.17 DIN125-A ZINC.	WASHER	RONDELLE	UNTERLEGSCHLEIBE	ARANDELLA
#	MB0A00022	C04533	SPINA ELASTICA D.8X45	SOCKET	GOUPILLE	STECKER	PASADOR
#	M30A00004	C23013	SUPPORTO UCF 207	SUPPORT	SUPPORT	STUTZE	APOYO
#	C05A03920	D01049	PIASTRINA POST. PER UCF 207	METAL STRAP	METAL DEPLOYE	BANDEISEN	PLATILLO
#	MD5A00003	D01060	CAVALLOTTO DIAGONALE M14 70X70	PIN	CAVALLIER	STIFT	CAVALLOTTI
#	C00A00006	D01062	DIST. D.42,4 D.35,5 L.14	SPACER	ENTRETOISE	ABSTANDSTUECK	ESPACIADORES
#	C10A01096	D01074	MORSETTO DIAGONALE 70X70***	TERMINAL	TERMINAL	TERMINAL	TERMINALES
#	MK0A00027	D01308	SPATOLA PULIRULLO PK ***	SPATULA	Spatules	SPACHTEL	ESPÁTULASS
#	C20A00052	E00922	TELAIO RULLO 205	FRAME	CHASSIS	RAHMEN	MARCO
#	C20A00053	E00923	TELAIO RULLO 230	FRAME	CHASSIS	RAHMEN	MARCO
#	C20A00054	E00924	TELAIO RULLO 250	FRAME	CHASSIS	RAHMEN	MARCO
#	C20A00055	E00925	TELAIO RULLO 300	FRAME	CHASSIS	RAHMEN	MARCO
#	C20A00159	E01325	PETTINE DA 5 ***	COMB	HERSE	KAMM	PEINE
#	C20A00161	E01326	PETTINE DA 4 ***	COMB	HERSE	KAMM	PEINE
#	C20A00181	E01430	RULLO PACKER PK3 205	ROLLER	ROULEAU	WALZE	RODILLO
#	C20A00182	E01431	RULLO PACKER PK3 230	ROLLER	ROULEAU	WALZE	RODILLO
#	C20A00183	E01432	RULLO PACKER PK3 250	ROLLER	ROULEAU	WALZE	RODILLO
#	C20A00184	E01433	RULLO PACKER PK3 300	ROLLER	ROULEAU	WALZE	RODILLO
#	C20A00374	E02273	TELAIO RULLO 180	FRAME	CHASSIS	RAHMEN	MARCO
#	C20A00698	E03708	TAMPONE CENTRALE RULLI DOPPI D.145X30	BUFFER	PRESSE	STOPFEN	TAMPON
#	C20A00779	E04220	RULLO PACKER PK3 180	ROLLER	ROULEAU	WALZE	RODILLO
#	C20A01262	E06951	TELAIO PORTA SPATOLE PK2/PK3 180	FRAME	CHASSIS	RAHMEN	MARCO
#	C20A01263	E06952	TELAIO PORTA SPATOLE PK2/PK3 205	FRAME	CHASSIS	RAHMEN	MARCO
#	C20A01264	E06953	TELAIO PORTA SPATOLE PK2/PK3 230	FRAME	CHASSIS	RAHMEN	MARCO
#	C20A01265	E06954	TELAIO PORTA SPATOLE PK2/PK3 250	FRAME	CHASSIS	RAHMEN	MARCO
#	C20A01266	E06955	TELAIO PORTA SPATOLE PK2/PK3 300	FRAME	CHASSIS	RAHMEN	MARCO
#	C20A01267	E06956	RINFORZO RULLO PK-2 / PK-3	REINFORCEMENT	RENFORT	VERSTAERKUNG	REFUERZO
#	C20A01375	E07755	TIRANTE RASCHIATORE M16 CON PIASTRINA	TIE ROD	TIRANT	ZUGSTANGE	TIRANTE
#	S10A00015	S03005	RULLO PACKER PK3-205 D.480 COMPLETO***	ROLLER	ROULEAU	WALZE	RODILLO
#	S10A00017	S03006	RULLO PACKER PK3-250 D.480 COMPLETO***	ROLLER	ROULEAU	WALZE	RODILLO
#	S10A00018	S03007	RULLO PACKER PK3-300 D.480 COMPLETO***	ROLLER	ROULEAU	WALZE	RODILLO
#	S10A00019	S03008	RULLO PACKER PK3-180 D.480 COMPLETO***	ROLLER	ROULEAU	WALZE	RODILLO
#	S10A00021	S03010	RULLO PACKER PK3-230 D.480 COMPLETO***	ROLLER	ROULEAU	WALZE	RODILLO

Copyright © 2009 Alpego s.p.a. ®

Tutti i diritti sono riservati. È vietata espressamente la ristampa o l'uso non autorizzato senza permesso scritto dalla Alpego s.p.a.
Tous droits réservés. Toute réimpression ou utilisation non autorisée sans la permission écrite de la Alpego s.p.a. est formellement interdite
Alle Rechte vorbehalten. Nachdruck, Vervielfältigung und Verbreitung, auch auszugsweise, ist ohne schriftliche Genehmigung der Alpego s.p.a.
Al rights reserved. Any reprinting or unauthorized use without the written permission of Alpego s.p.a. is expressly prohibited
Todos los derechos reservados. Toda reproducción o uso no autorizado sin el consentimiento escrito de Alpego s.p.a. quedan expresamente prohibidos

22/05/2014

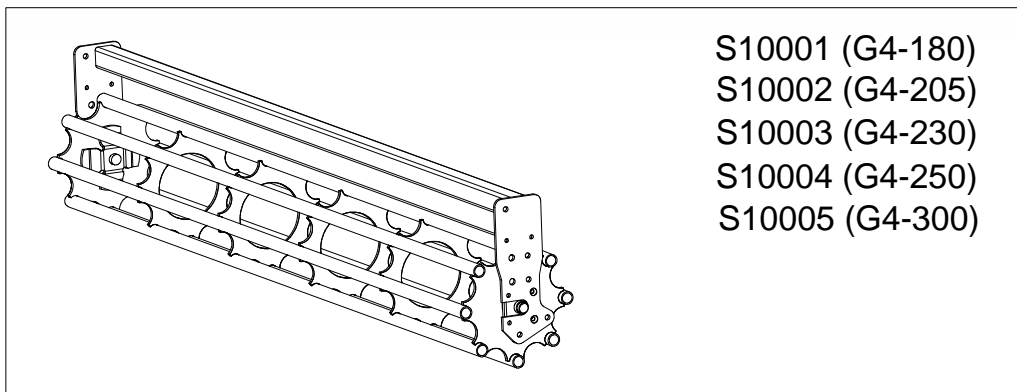
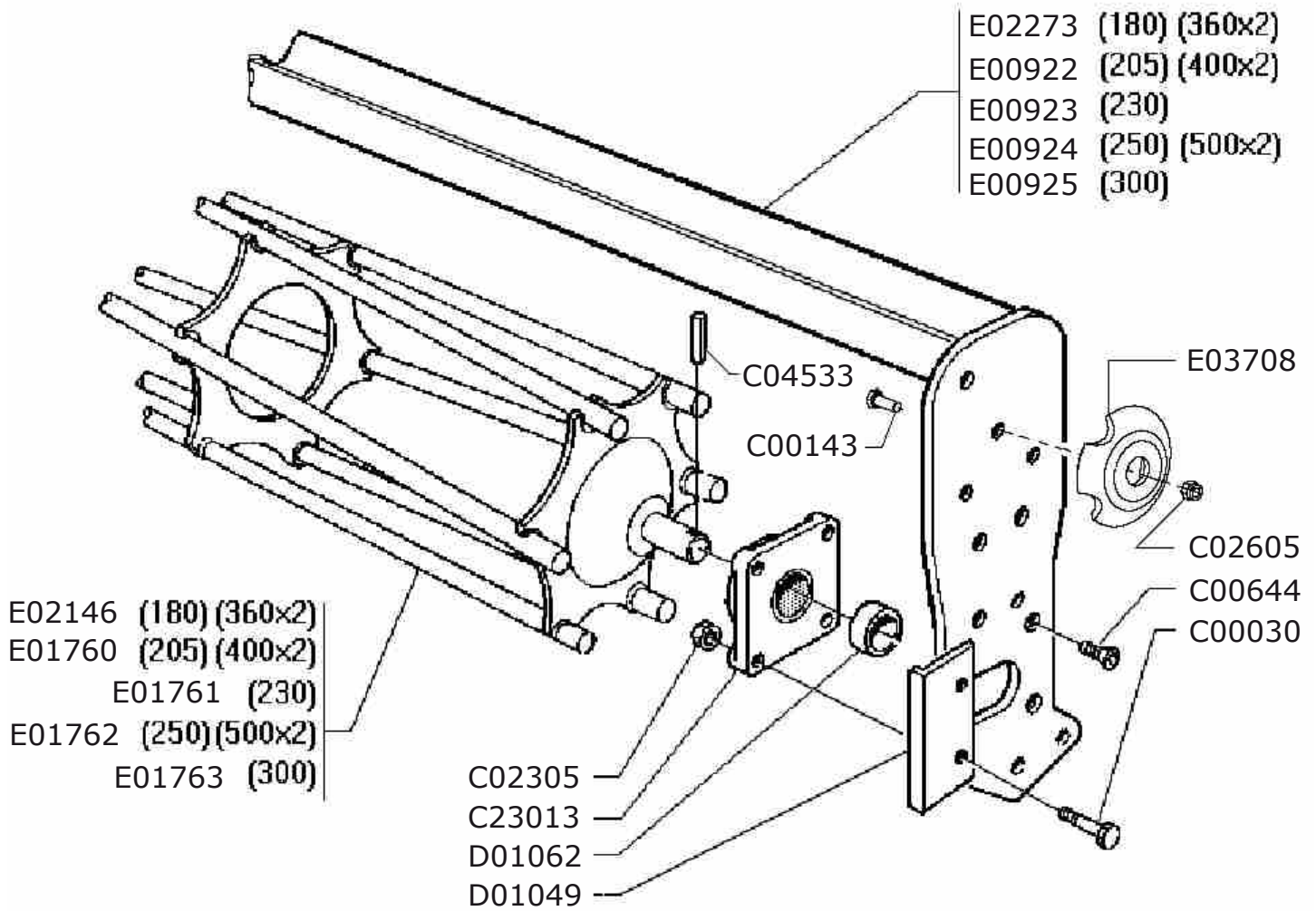



Rullo gabbia G4

Roller cage G4

Rouleau cage G4

Stab walze G4

Drawing Code:

100117_0

Accessories:

N°	Code	Old.	Descrizione / Description
#	M80A00027	C00030	VITE TE 88 PG FP M12X40 ZINC UNI 5737
#	M80A00130	C00143	VITE TE 88 PG FT M12X35 ZINC UNI 5739
#	M80A00292	C00644	VITE TSPEI 10.9 PG M12X40 ZINC UNI 5933
#	M85A00050	C02305	DADO METALBLOC M12 X 1.75
#	M85A00078	C02605	DADO AUTOBLOC ALTO 8 M12 H=14 UNI 7473
#	MB0A00022	C04533	SPINA ELASTICA D.8X45
#	M30A00004	C23013	SUPPORTO UCF 207
#	C05A003920	D01049	PIASTRINA POST. PER UCF 207
#	C00A00006	D01062	DIST. D.42,4 D.35,5 L.14
#	C20A00052	E00922	TELAIO RULLO 205
#	C20A00053	E00923	TELAIO RULLO 230
#	C20A00054	E00924	TELAIO RULLO 250
#	C20A00055	E00925	TELAIO RULLO 300
#	C20A00261	E01760	RULLO GABBIA G4-205
#	C20A00262	E01761	RULLO GABBIA G4-230
#	C20A00263	E01762	RULLO GABBIA G4-250
#	C20A00264	E01763	RULLO GABBIA G4-300
#	C20A00350	E02146	RULLO GABBIA G4-180
#	C20A00374	E02273	TELAIO RULLO 180
#	C20A00698	E03708	TAMPONE CENTRALE RULLI DOPPI D.145X30
#	S05A00012	S10001	RULLO GABBIA G4-180 COMPLETO
#	S05A00013	S10002	RULLO GABBIA G4-205 COMPLETO
#	S05A00014	S10003	RULLO GABBIA G4-230 COMPLETO
#	S05A00015	S10004	RULLO GABBIA G4-250 COMPLETO
#	S05A00016	S10005	RULLO GABBIA G4-300 COMPLETO

GB	FR	D	E
SCREW	VIS	SCHRAUBE	TORNILLO
SCREW	VIS	SCHRAUBE	TORNILLO
SCREW	VIS	SCHRAUBE	TORNILLO
NUT	BOULONS	NUT	DADO
NUT	BOULONS	NUT	DADO
SOCKET	GOUILLE	STECKER	PASADOR
SUPPORT	SUPPORT	STUTZE	APOYO
METAL STRAP	METAL DEPLOYE	BANDEISEN	PLATILLO
SPACER	ENTRETOISE	ABSTANDSTUECK	ESPACIADORES
FRAME	CHASSIS	RAHMEN	MARCO
FRAME	CHASSIS	RAHMEN	MARCO
FRAME	CHASSIS	RAHMEN	MARCO
FRAME	CHASSIS	RAHMEN	MARCO
ROLLER	ROULEAU	WALZE	RODILLO
ROLLER	ROULEAU	WALZE	RODILLO
ROLLER	ROULEAU	WALZE	RODILLO
ROLLER	ROULEAU	WALZE	RODILLO
ROLLER	ROULEAU	WALZE	RODILLO
ROLLER	ROULEAU	WALZE	RODILLO
FRAME	CHASSIS	RAHMEN	MARCO
BUFFER	PRESSE	STOPFEN	TAMPON
ROLLER	ROULEAU	WALZE	RODILLO
ROLLER	ROULEAU	WALZE	RODILLO
ROLLER	ROULEAU	WALZE	RODILLO
ROLLER	ROULEAU	WALZE	RODILLO
ROLLER	ROULEAU	WALZE	RODILLO

Coppia rompitraccia (80x80)

Wheel track eradicators (80x80)

Dents extirpatrices avant (80x80)

Paar spurlockerer (80x80)

Drawing Code: **100104_0**

Accessories: S91A00009

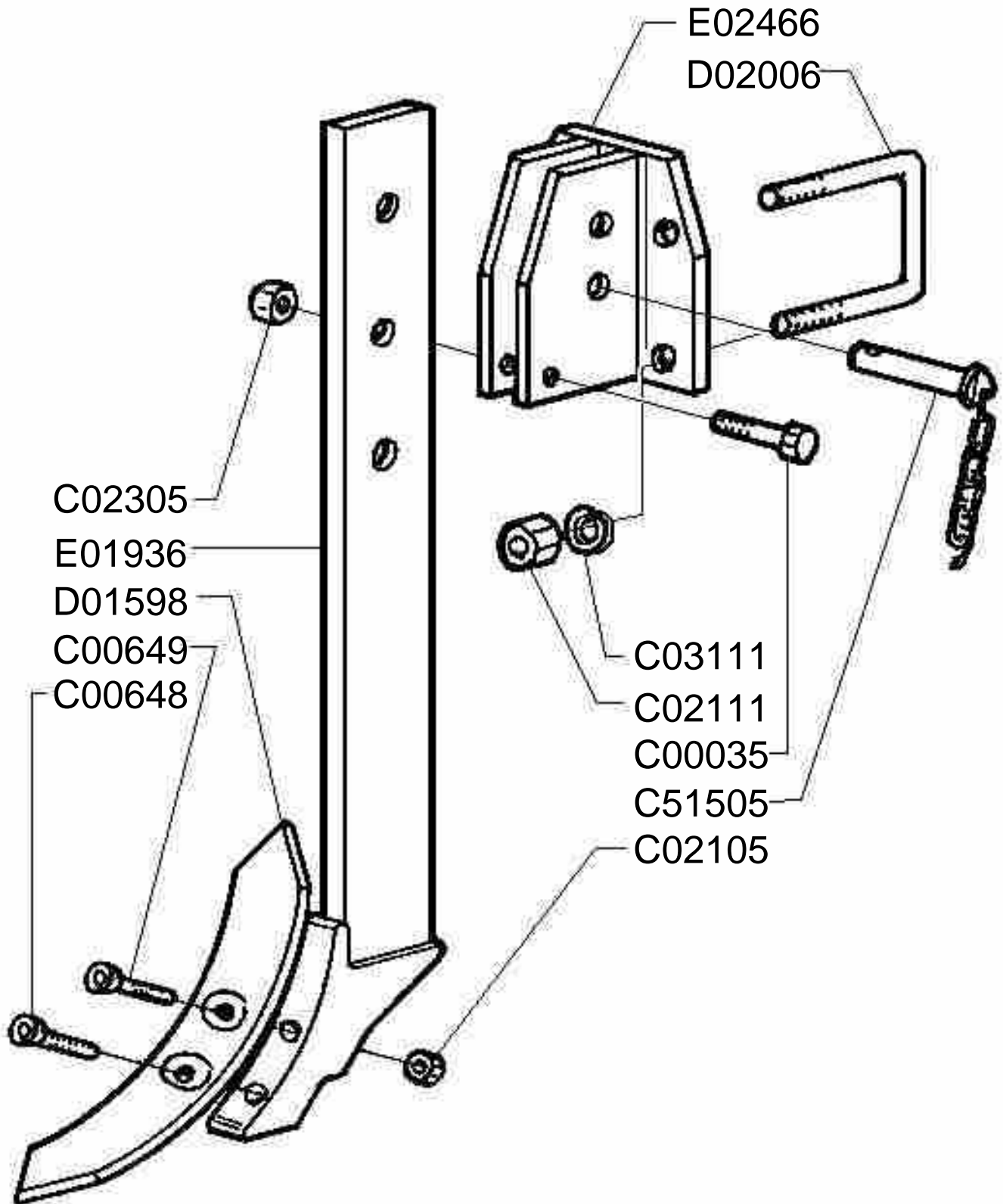

100104_00



Coppia rompitraccia (80x80)

Wheel track eradicators (80x80)

Dents extirpatrices avant (80x80)

Paar spurlockerer (80x80)

Drawing Code:

100104_0

Accessories:

S91A00009

N°	Code	Old.	Descrizione / Description
#	M80A00032	C00035	VITE TE 88 PG FP M12X70 ZINC UNI 5737
#	M80A00296	C00648	VITE TSPEI 10.9 PG M12X60 UNI 5933
#	M80A00297	C00649	VITE TSPEI 10.9 PG M12X70 UNI 5933
#	M85A00028	C02105	DADO NORMALE 8 PG M12 UNI 5588
#	M85A00034	C02111	DADO NORMALE 8 PG M18 UNI 5588 ZINC
#	M85A00050	C02305	DADO METALBLOC M12 X 1.75
#	M90A00041	C03111	RONDELLA GROWER D.18 DIN 127
#	M15A00004	C51505	PERNO 3P. D.19 CON CAT.
#	MK0A00038	D01598	VOMERE ROMPITRACCIA 60X12X300
#	MD5A00007	D02006	CAVALLOTTO QUADRO M18X80X135
#	C20A00322	E01936	BRACCIO ROMPITRACCIA 80X25 DF ***
#	C20A00440	E02466	STAFFA GUIDA ROMPITRACCIA TUBO 80X80

GB	FR	D	E
SCREW	VIS	SCHRAUBE	TORNILLO
SCREW	VIS	SCHRAUBE	TORNILLO
SCREW	VIS	SCHRAUBE	TORNILLO
NUT	BOULONS	NUT	DADO
NUT	BOULONS	NUT	DADO
NUT	BOULONS	NUT	DADO
WASHER	RONDELLE	UNTERLEGSCHIEBE	ARANDELLA
PIN	PIVOT	STIFT	PIN
PLOUGHSHARE	SOC	PFLUGSCHAR	REJA
PIN	CAVALLIER	STIFT	CAVALLOTTI
ARM	BRAS	ARM	BRAZO
BRACKET	SUPPORT	BUEGEL	SOPORTE